



Finishes You've Never Seen Before®

WESTERN STATES METAL ROOFING

(877) 787-5467 • WESTERNSTATESMETALROOFING.COM

STANDING SEAM METAL ROOF PANEL **WESTERN SEAM®**

UL TESTS:

ANSI/UL 580, Uplift Resistance of Roof Assembly
ANSI/UL 790, Fire Tests of Roof Coverings
UL 2218A, Impact Resistance of Roof Systems

WSMR UL Certificate Number: R40094

Issue Date: 7/23/2020

See attached UL Report and Test Results from our Roll Forming Machinery vendor for this specific panel type referenced as "FF 100 Panel" with UL report number R14692

REQUEST A FREE METAL COLOR SAMPLE
Affordable Delivery throughout USA, Canada, and Mexico

Phoenix: 901 W Watkins St., Phoenix, AZ 85007

☎ (602) 495-0048

✉ sales@westernstatesmetalroofing.com

Tucson: 4975 E. Drexel Rd., Tucson, AZ 85706

☎ (520) 574-4247

✉ tucsonsales@westernstatesmetalroofing.com



CERTIFICATE OF COMPLIANCE

Certificate Number R40094
Report Reference R40094-20191126
Issue Date 2020-JULY-23

Issued to: Western States Metal Roofing
901 W. Watkins St, Phoenix AZ 85007

This certificate confirms that representative samples of

Metal Roof Deck Panels; Wind Uplift Resistance; Roofing Systems; Impact Resistance

Models: "7/8" Corrugated", "Western Rib", "Western R-Panel", "MS2®", "Thin Lock®", "Western Lock®", and "Western Seam®".

Have been investigated by UL in accordance with the Standard(s) indicated on this Certificate.

Standard(s) for Safety: ANSI/UL 580, Tests for Uplift Resistance of Roof Assemblies
ANSI/UL 790, Test Methods or Fire Tests of Roof Coverings
UL 2218A, Impact Resistance of Roofing Systems

Additional Information: See the UL Online Certifications Directory at <https://iq.ulprospector.com> for additional information.

This *Certificate of Compliance* does not provide authorization to apply the UL Mark. Only the UL Follow-Up Services Procedure provides authorization to apply the UL Mark.

Only those products bearing the UL Mark should be considered as being UL Certified and covered under UL's Follow-Up Services.

Look for the UL Certification Mark on the product.



Bruce Mahrenholz, Director North American Certification Program
UL LLC

Any information and documentation involving UL Mark services are provided on behalf of UL LLC (UL) or any authorized licensee of UL. For questions, please contact a local UL Customer Service Representative at <http://ul.com/aboutul/locations/>



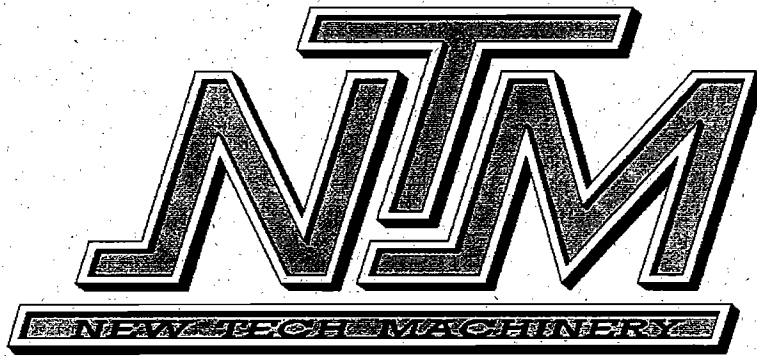

FF 100 PANEL



UL LISTED CONSTRUCTION NUMBERS

#529
SECTION ANALYSIS REPORT
AND
SPAN LOAD TABLES

1300 40TH DENVER, CO 80205-3311

PH 303-294-0538 **** 800-574-1717 **** FAX 303-294-9407

DESCRIPTION**PRODUCT COVERED:**

This section of the Procedure covers a coated steel roof panel, which is identified as "FF100" panel. The panel is produced at job sites by portable rolling machines.

The panel is roll-formed from No.29 MSG minimum or heavier gauge steel coated to the configuration shown in Ill. 1. The panel may also have a paint finish over the coating.

SPECIFICATIONS OF FINISHED PRODUCT:**THICKNESS**

The base metal thickness of the steel used in the fabrication of the panel shall be not less than 0.0128 in. No. 29 msg minimum gauge. This thickness shall not include any coating or paint finish.

DIMENSIONS

The cross-sectional dimensions of the panel piece shall be in accordance with the cross-section in Ill. 1.

STRENGTH

The strength records of the steel shall be reviewed. The 29 MSG steel used shall conform to ASTM A792 grade 50 Specifications or the minimum yield point of the steel shall be 50,000 psi.



**Underwriters
Laboratories Inc.®**

Northbrook Division
333 Pfingsten Road
Northbrook, IL 60062-2096 USA
www.ul.com
tel: 1 847 272 8800
fax: 1 847 272 8129
Customer service: 1 877 854 3577

NEW TECH MACHINERY CORP
MR G BATTISTELL
1300 40TH ST
DENVER CO 80205

RE: Project Number(s) - 03NK22866

Your most recent Certification is shown below. You may also view this information, or a portion of this information (depending on the product category), on UL's Online Certifications Directory at www.ul.com/database. Please review the text and contact the Conformity Assessment Services staff member who handled your project if revisions are required. For instructions on placing an order for this information in a 3 x 5-inch format, you may refer to the enclosed order form for UL Card Service.

TJPV
Metal Roof Deck Panels

November 21, 2003

NEW TECH MACHINERY CORP
1300 40TH ST, DENVER CO 80205

R14692

Coated steel panels, field - formed.
Underwriters Laboratories Inc. Metal Roof Deck Panels, Fabricated, installed and used in the following roof deck constructions with corresponding panel identifications:
Coated steel panels identified as "Snap Panel 550" for use in Construction No. 373.
Coated steel panels identified as "Panel 210A" for use in Construction Nos. 90, 176, 180, 238, 238A.
Coated steel or aluminum panels identified as "Snap Panel 675" for use in Construction Nos 254, 255, 261, 303.
Coated steel panels identified as "SS675" for use in Construction Nos. 343, 508 and 508A.
Coated steel panels identified as "SS450" for use in Construction No. 370.
Coated steel panels identified as "SS150" for use in Construction No. 554.
Coated steel panels identified as "SS100" for use in Construction No. 575.
Coated steel panels identified as "FF100" for use in Construction No. 529.

See Roof Deck Construction for description of construction numbers.

LOOK FOR LISTING MARK ON PRODUCT



Online Certifications Directory

TGKX.529 Roof Deck Constructions

[Page Bottom](#)

[Questions?](#)

[Previous Page](#)

Roof Deck Constructions

Guide Information

Construction No. 529

November 21, 2003

Uplift — Class 90

Fire Not Investigated

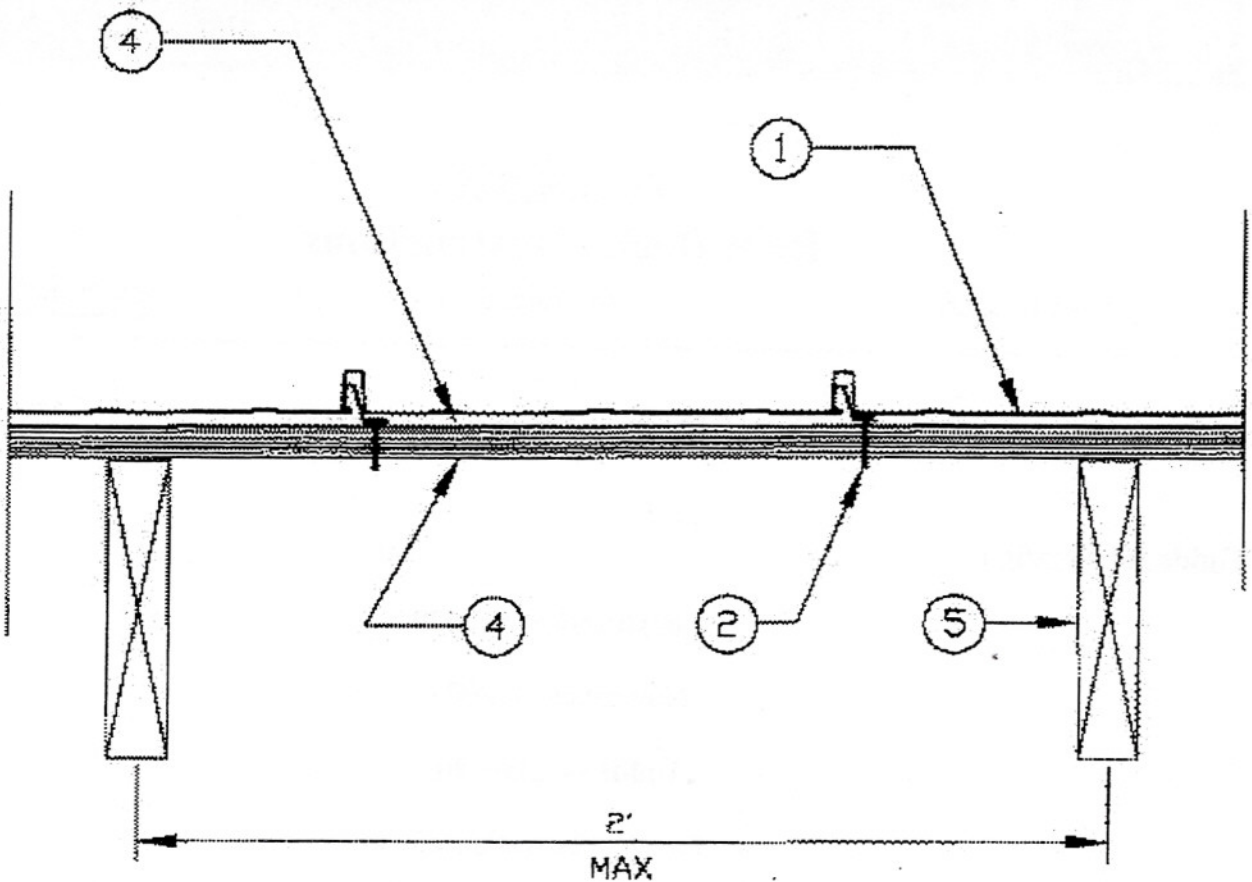

1. **Metal Roof Deck Panels*** — No. 29 MSG min coated steel. Max panel width 24 in. Rib height nominal 1 in. Panels continuous over two or more spans. A bead of sealant may be used at panel endlaps.

AMERICAN BUILDING COMPONENTS — "SL-16"

CENTRAL TEXAS METAL ROLLFORMING INC — "PRO-SNAP 100"

MBCI — "Slimline"

NCI BUILDING SYSTEMS L P — "Slimline"

NEW TECH MACHINERY CORP — "FF100"

UNION CORRUGATING CO — "Advantage Lok"

2. **Fasteners** — (Screws) — For panel attachment to wood deck (Item 3), fasteners to

be No. 10 x 1 in. long No. 2 Phillips, Pancake Head Type A. Fasteners spacing to be 12 in. OC with fasteners installed through prepunched slots in fastener flange of panel. For attachment of plywood deck (Item 3) to joists (Item 5), fasteners to be min. No. 6 by 1-7/8 bugle head screw or annular ring-shank nails. Spacing to be 6 in. OC at plywood edges and 12 in. OC at intermediate supports. When light gauge structural steel joists are used, fasteners to be No. 12 by 1-5/8 in. long with a Phillips head.

3. Substructure — (Plywood) — Plywood decking to be a nom 5/8 in. thick, exposure sheathing span C-D, 40/20 plywood. All butt joints to be sealed against leakage by using tape and/or caulk or with one-part urethane sealant.

4. Moisture Barrier — (Optional) — Any suitable membrane to protect substructure (Item 3).

5. Joists — Joists spaced at 2 ft, 0 in. OC, may be one of the following:

A. Nom 2 by 6 in. wood joists No. 2 or better.

B. Nom 2 by 4 in. wood when used on a top cord of a wood truss, No. 2 or better.

C. Light gauge structural steel framing with the member against the plywood to be a min No. 22 MSG coated steel.

Refer to General Information, Roof Deck Construction, (Roofing Materials and Systems Directory) for Items Not Evaluated.

*Bearing the UL Classification Mark

[Page Top](#)

[Notice of Disclaimer](#)

[Questions?](#)

[Previous Page](#)

[UL Listed and Classified Products](#)

[UL Recognized Components](#)

[Products Certified for Canada](#)

This page and all contents are Copyright © 2004 by Underwriters Laboratories Inc.®

The appearance of a company's name or product in this database does not in itself assure that products so identified have been manufactured under UL's Follow-Up Service. Only those products bearing the UL Mark should be considered to be Listed and covered under UL's Follow-Up Service. Always look for the Mark on the product.

UL permits the reproduction of the material contained on UL's Website subject to the following conditions: 1. The Guide Information, Designs and/or Listings (files) must be presented in their entirety and in a non-misleading manner, without any manipulation of the data (or drawings). 2. The statement "Reprinted from the Online Certifications Directory with permission from Underwriters Laboratories Inc." must appear adjacent to the extracted material. In addition, the reprinted material must include a copyright notice in the following format: "Copyright © 2004 Underwriters Laboratories Inc.®"



JOHN F. BUTTS & ASSOC., INC.

CONSULTING ENGINEERS
2480 VANTAGE DRIVE COLORADO SPRINGS, CO 80919
(719) 598-7666 FAX (719) 598-0258
www.jfba.com

August 29, 2002

New Tech Machinery Corp.
1300 40th Street
Denver, CO 80205-3311

**Re: Section Analysis Report
New Tech FF100 Panel
Job No. 183-05**

Gentlemen:

Per your request, please find enclosed the engineering calculations for the above referenced project. The section, with the structural properties indicated in this report is certified to meet or exceed the requirements of the 1996 AISI Cold-Formed Steel Design Manual including Supplement No. 1 (July 1999).

Please note that the panel analysis and Load Tables have been evaluated based on the assumption that the proper bearing, side laps, end laps, bracing, anchorage and structural supports are being utilized in the member's installation. We do not certify the installation method, attachment and supporting materials.

If we can be of further assistance or if you require additional information, please call.

Sincerely,

John F. Butts, P.E.
President

enc. Section Drawing
Section Analysis
Section Load Tables

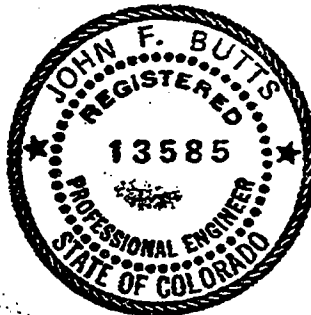

John F. Butts & Associates, Inc.
2480 Vantage Drive
Colorado Springs, CO 80919
(719) 598-7666

Analysis per 1996 AISI Cold-Formed Steel Manual + 1999 Supplement 1

New Tech FF100 Panel

FILE: FF100X12

SECTION DIMENSIONS

Line #1 Angle(L) =	-80.000 deg	Line #21 Angle(R) =	81.000 deg
Line #1 Radius(L) =	0.060 in	Line #21 Radius(R) =	0.063 in
Line #1 Length(L) =	0.000 in	Line #22 Length(R) =	0.194 in
Line #2 Angle(L) =	80.000 deg	Line #22 Angle(R) =	70.000 deg
Line #2 Radius(L) =	0.070 in	Line #22 Radius(R) =	0.060 in
Line #2 Length(L) =	0.683 in	Line #24 Length(R) =	0.034 in
Line #3 Angle(L) =	81.000 deg	Line #23 Angle(R) =	-86.000 deg
Line #3 Radius(L) =	0.070 in	Line #23 Radius(R) =	0.070 in
Line #3 Length(L) =	0.000 in	Line #26 Length(R) =	0.134 in
Line #4 Angle(L) =	-180.000 deg	Line #24 Angle(R) =	-151.000 deg
Line #4 Radius(L) =	0.070 in	Line #24 Radius(R) =	0.122 in
Line #4 Length(L) =	0.125 in	Line #28 Length(R) =	0.447 in
Line #5 Angle(L) =	0.000 deg	Line #25 Angle(R) =	86.000 deg
Line #5 Radius(L) =	0.000 in	Line #25 Radius(R) =	0.141 in
Line #5 Length(L) =	0.000 in	Line #30 Length(R) =	0.636 in

Panel Bottom Width	=	12.00 in
Panel Overall Width	=	12.56 in
Panel Overall Height	=	0.81 in

Alloy: ASTM A792, G50

Fy = 50.00 ksi

Fv = 14.13 ksi

QUALIFICATIONS PER AISI SPECIFICATIONS

(a) Maximum w/t Ratio's Exceeded [Section B1.1(a)]: No

(b) Maximum h/t Ratio's Exceeded [Section B1.2(a)]: No

Section Dimensional Data

Type	Name	Gage	Height in	Width in	Lip in	t in	Weight plf	Coil Width in
Panel		24	0.813	12.563	0.000	0.024	1.338	16.389

Gross Sectional Properties

Area in ²	Ix in ⁴	Sx in ³	Rx in	Ycg in	Iy in ⁴	Sy in ³	Ry in	Xcg in
0.393	0.015	0.022	0.198	0.097	7.701	1.098	4.425	7.012

Effective Properties

Vnx kip	Ix in ⁴	Sx in ³	Mnx kip-in	Mny kip-in	Iy in ⁴	Sy in ³	Pne kip	Pnei kip/in
1.450	0.015	0.022	0.906	---	---	---	0.738	0.650

Torsional Properties

Xo in	Ro in	Beta	Cw in ⁶	Jv*1000 in ⁴	Fy ksi	Fu ksi	E ksi	G ksi
-0.293	4.439	0.996	0.599	0.076	50	65	29500	11300

Shear, moment and bearing values shown are nominal values and must be modified by the appropriate factors of safety (ASD) or resistance factors (LRFD).

Factors of Safety (ASD)		Resistance Factors (LRFD)	
FS (Compression)	= 1.80	RF (Compression)	= 0.85
FS (Tension)	= 1.67	RF (Tension)	= 0.95
FS (Web Crippling)	= 1.85	RF (Web Crippling)	= 0.75
FS (Bending)	= 1.67	RF (Bending)	= 0.90
FS (Shear)	= 1.50	RF (Shear)	= 1.00

John F. Butts & Associates, Inc.
2480 Vantage Drive
Colorado Springs, CO 80919
(719) 598-7666

Analysis per 1996 AISI Cold-Formed Steel Manual + 1999 Supplement 1

New Tech FF100 Panel

FILE: FF100X16

SECTION DIMENSIONS

Line #1 Angle(L) =	-80.000 deg	Line #21 Angle(R) =	81.000 deg
Line #1 Radius(L) =	0.060 in	Line #21 Radius(R) =	0.063 in
Line #1 Length(L) =	0.000 in	Line #22 Length(R) =	0.194 in
Line #2 Angle(L) =	80.000 deg	Line #22 Angle(R) =	70.000 deg
Line #2 Radius(L) =	0.070 in	Line #22 Radius(R) =	0.060 in
Line #2 Length(L) =	0.683 in	Line #24 Length(R) =	0.034 in
Line #3 Angle(L) =	81.000 deg	Line #23 Angle(R) =	-86.000 deg
Line #3 Radius(L) =	0.070 in	Line #23 Radius(R) =	0.070 in
Line #3 Length(L) =	0.000 in	Line #26 Length(R) =	0.134 in
Line #4 Angle(L) =	-180.000 deg	Line #24 Angle(R) =	-151.000 deg
Line #4 Radius(L) =	0.070 in	Line #24 Radius(R) =	0.122 in
Line #4 Length(L) =	0.125 in	Line #28 Length(R) =	0.447 in
Line #5 Angle(L) =	0.000 deg	Line #25 Angle(R) =	86.000 deg
Line #5 Radius(L) =	0.000 in	Line #25 Radius(R) =	0.141 in
Line #5 Length(L) =	0.000 in	Line #30 Length(R) =	0.636 in

Panel Bottom Width	=	16.00 in
Panel Overall Width	=	16.56 in
Panel Overall Height	=	0.81 in

Alloy: ASTM A792, G50

Fy = 50.00 ksi

Fv = 7.35 ksi

QUALIFICATIONS PER AISI SPECIFICATIONS

(a) Maximum w/t Ratio's Exceeded [Section B1.1(a)]: No

(b) Maximum h/t Ratio's Exceeded [Section B1.2(a)]: No

Section Dimensional Data

Type	Name	Gage	Height in	Width in	Lip in	t in	Weight plf	Coil Width in
Panel		24	0.813	16.563	0.000	0.024	1.665	20.389

Gross Sectional Properties

Area in ²	Ix in ⁴	Sx in ³	Rx in	Ycg in	Iy in ⁴	Sy in ³	Ry in	Xcg in
0.489	0.016	0.022	0.181	0.080	15.531	1.724	5.634	9.007

Effective Properties

Vnx kip	Ix in ⁴	Sx in ³	Mnx kip-in	Mny kip-in	Iy in ⁴	Sy in ³	Pne kip	Pnei kip/in
1.450	0.016	0.022	0.911	---	---	---	0.738	0.650

Torsional Properties

Xo in	Ro in	Beta	Cw in ⁶	Jv*1000 in ⁴	Fy ksi	Fu ksi	E ksi	G ksi
-0.242	5.642	0.998	1.091	0.094	50	65	29500	11300

Shear, moment and bearing values shown are nominal values and must be modified by the appropriate factors of safety (ASD) or resistance factors (LRFD).

Factors of Safety (ASD)

FS (Compression)	= 1.80
FS (Tension)	= 1.67
FS (Web Crippling)	= 1.85
FS (Bending)	= 1.67
FS (Shear)	= 1.50

Resistance Factors (LRFD)

RF (Compression)	= 0.85
RF (Tension)	= 0.95
RF (Web Crippling)	= 0.75
RF (Bending)	= 0.90
RF (Shear)	= 1.00

John F. Butts & Associates, Inc.
2480 Vantage Drive
Colorado Springs, CO 80919
(719) 598-7666

Analysis per 1996 AISI Cold-Formed Steel Manual + 1999 Supplement 1

New Tech FF100 Panel

FILE: FF100X18

SECTION DIMENSIONS

Line #1 Angle(L) =	-80.000 deg	Line #21 Angle(R) =	81.000 deg
Line #1 Radius(L) =	0.060 in	Line #21 Radius(R) =	0.063 in
Line #1 Length(L) =	0.000 in	Line #22 Length(R) =	0.194 in
Line #2 Angle(L) =	80.000 deg	Line #22 Angle(R) =	70.000 deg
Line #2 Radius(L) =	0.070 in	Line #22 Radius(R) =	0.060 in
Line #2 Length(L) =	0.683 in	Line #24 Length(R) =	0.034 in
Line #3 Angle(L) =	81.000 deg	Line #23 Angle(R) =	-86.000 deg
Line #3 Radius(L) =	0.070 in	Line #23 Radius(R) =	0.070 in
Line #3 Length(L) =	0.000 in	Line #26 Length(R) =	0.134 in
Line #4 Angle(L) =	-180.000 deg	Line #24 Angle(R) =	-151.000 deg
Line #4 Radius(L) =	0.070 in	Line #24 Radius(R) =	0.122 in
Line #4 Length(L) =	0.125 in	Line #28 Length(R) =	0.447 in
Line #5 Angle(L) =	0.000 deg	Line #25 Angle(R) =	86.000 deg
Line #5 Radius(L) =	0.000 in	Line #25 Radius(R) =	0.141 in
Line #5 Length(L) =	0.000 in	Line #30 Length(R) =	0.636 in

Panel Bottom Width	=	18.00 in
Panel Overall Width	=	18.56 in
Panel Overall Height	=	0.81 in

Alloy: ASTM A792, G50

Fy = 50.00 ksi

Fv = 5.99 ksi

QUALIFICATIONS PER AISI SPECIFICATIONS

(a) Maximum w/t Ratio's Exceeded [Section B1.1(a)]: No

(b) Maximum h/t Ratio's Exceeded [Section B1.2(a)]: No

Section Dimensional Data

Type	Name	Gage	Height in	Width in	Lip in	t in	Weight plf	Coil Width in
Panel		24	0.813	18.563	0.000	0.024	1.828	22.389

Gross Sectional Properties

Area in ²	Ix in ⁴	Sx in ³	Rx in	Ycg in	Iy in ⁴	Sy in ³	Ry in	Xcg in
0.537	0.016	0.022	0.174	0.074	20.866	2.085	6.231	10.005

Effective Properties

Vnx kip	Ix in ⁴	Sx in ³	Mnx kip-in	Mny kip-in	Iy in ⁴	Sy in ³	Pne kip	Pnei kip/in
1.450	0.016	0.022	0.910	---	---	---	0.738	0.650

Torsional Properties

Xo in	Ro in	Beta	Cw in ⁶	Jv*1000 in ⁴	Fy ksi	Fu ksi	E ksi	G ksi
-0.222	6.238	0.999	1.395	0.103	50	65	29500	11300

Shear, moment and bearing values shown are nominal values and must be modified by the appropriate factors of safety (ASD) or resistance factors (LRFD).

Factors of Safety (ASD)		Resistance Factors (LRFD)	
FS (Compression)	= 1.80	RF (Compression)	= 0.85
FS (Tension)	= 1.67	RF (Tension)	= 0.95
FS (Web Crippling)	= 1.85	RF (Web Crippling)	= 0.75
FS (Bending)	= 1.67	RF (Bending)	= 0.90
FS (Shear)	= 1.50	RF (Shear)	= 1.00

Width | 12.56 in
 Alloy | ASTM A792, G50 (Fy =50 ksi)
 Gauge | 24 (0.024 in)

Allowable Strength Design (ASD)
 Wind Load Factor = 1.00
 Allowable Uniform Load (psf)

Span	Deflection	Span Length (Feet)								
		2.00	2.25	2.50	2.75	3.00	3.25	3.50	3.75	4.00
1	L/180	82	65	52	43	36	30	26	22	19
	L/240	82	65	52	43	35	27	22	18	15
	L/360	78	55	40	30	23	18	15	12	10
2	L/180	82	65	52	43	36	30	26	22	20
	L/240	82	65	52	43	36	30	26	22	20
	L/360	82	65	52	42	33	26	21	17	14
3	L/180	95	75	61	50	42	35	30	26	23
	L/240	95	75	61	50	42	35	30	26	23
	L/360	95	75	61	50	42	34	27	22	18

1. Formula's used in Load Tables for FLEXURE and DEFLECTION are:

One Span - $M_p = .125wl^2$, $M_n = .125wl^2$, $x = .0130wl^4/EI$
 Two Span - $M_p = .125wl^2$, $M_n = .096wl^2$, $x = .0092wl^4/EI$
 Three Span - $M_p = .080wl^2$, $M_n = .107wl^2$, $x = .0069wl^4/EI$
 Modulus of Elasticity (E) = 29500 ksi

2. Allowable uniform loads are determined per the following:

- a) Allowable Shear Stress (Fv) [AISI, C3.2]
- b) Combined Bending and Shear [AISI, C3.3]
- c) Combined Bending & Web Crippling [AISI C3.5]

3. Factors of Safety used to determine uniform loads:

FS (Bending) = 1.67
 FS (Shear) = 1.50
 FS (Web Crippling) = 1.85

4. Allowance has been made for member Dead Weight.

5. Minimum panel support bearing length = 2.00 in

6. Concentrated load = 250 lbs at mid-span, load width = 4 in

Simple Span : Maximum Span = 1.361 ft (L/180)
 Two Span : Maximum Span = 1.560 ft (L/180)
 Three Span + : Maximum Span = 1.648 ft (L/180)

Width | 12.56 in
 Alloy | ASTM A792, G50 (Fy =50 ksi)
 Gauge | 24 (0.024 in)

Allowable Strength Design (ASD)
 Wind Load Factor = 1.00
 Allowable Uniform Load (psf)

Span	Deflection	Span Length (Feet)								
		4.25	4.50	4.75	5.00	5.25	5.50	5.75	6.00	6.25
1	L/180	16	14	12	10	9	7	7	6	5
	L/240	12	10	9	7	6	6	5	4	4
	L/360	8	7	6	5	4	4	3	3	3
2	L/180	17	15	14	12	11	10	9	8	7
	L/240	17	15	12	11	9	8	7	6	5
	L/360	11	10	8	7	6	5	5	4	4
3	L/180	20	18	16	14	13	12	11	10	9
	L/240	20	18	16	14	12	11	9	8	7
	L/360	15	13	11	9	8	7	6	5	5

- Formula's used in Load Tables for FLEXURE and DEFLECTION are:
 One Span - $M_p = .125wl^2$, $M_n = .125wl^2$, $x = .0130wl^4/EI$
 Two Span - $M_p = .125wl^2$, $M_n = .096wl^2$, $x = .0092wl^4/EI$
 Three Span - $M_p = .080wl^2$, $M_n = .107wl^2$, $x = .0069wl^4/EI$
 Modulus of Elasticity (E) = 29500 ksi
- Allowable uniform loads are determined per the following:
 a) Allowable Shear Stress (Fv) [AISI, C3.2]
 b) Combined Bending and Shear [AISI, C3.3]
 c) Combined Bending & Web Crippling [AISI C3.5]
- Factors of Safety used to determine uniform loads:
 FS (Bending) = 1.67
 FS (Shear) = 1.50
 FS (Web Crippling) = 1.85
- Allowance has been made for member Dead Weight.
- Minimum panel support bearing length = 2.00 in
- Concentrated load = 250 lbs at mid-span, load width = 4 in
 Simple Span : Maximum Span = 1.361 ft (L/180)
 Two Span : Maximum Span = 1.560 ft (L/180)
 Three Span + : Maximum Span = 1.648 ft (L/180)

Width | 16.56 in
 Alloy | ASTM A792, G50 (Fy =50 ksi)
 Gauge | 24 (0.024 in)

Allowable Strength Design (ASD)
 Wind Load Factor = 1.00
 Allowable Uniform Load (psf)

Span	Deflection	Span Length (Feet)								
		2.00	2.25	2.50	2.75	3.00	3.25	3.50	3.75	4.00
1	L/180	63	50	40	33	27	23	20	17	15
	L/240	63	50	40	33	27	22	17	14	12
	L/360	62	43	32	24	18	14	12	9	8
2	L/180	63	50	40	33	27	23	20	17	15
	L/240	63	50	40	33	27	23	20	17	15
	L/360	63	50	40	33	26	20	16	13	11
3	L/180	73	57	46	38	32	27	23	20	17
	L/240	73	57	46	38	32	27	23	20	17
	L/360	73	57	46	38	32	27	22	18	15

1. Formula's used in Load Tables for FLEXURE and DEFLECTION are:

One Span - $M_p = .125wl^2$, $M_n = .125wl^2$, $x = .0130wl^4/EI$
 Two Span - $M_p = .125wl^2$, $M_n = .096wl^2$, $x = .0092wl^4/EI$
 Three Span - $M_p = .080wl^2$, $M_n = .107wl^2$, $x = .0069wl^4/EI$
 Modulus of Elasticity (E) = 29500 ksi

2. Allowable uniform loads are determined per the following:

- a) Allowable Shear Stress (Fv) [AISI, C3.2]
- b) Combined Bending and Shear [AISI, C3.3]
- c) Combined Bending & Web Crippling [AISI C3.5]

3. Factors of Safety used to determine uniform loads:

FS (Bending) = 1.67
 FS (Shear) = 1.50
 FS (Web Crippling) = 1.85

4. Allowance has been made for member Dead Weight.

5. Minimum panel support bearing length = 2.00 in

6. Concentrated load = 250 lbs at mid-span, load width = 4 in

Simple Span : Maximum Span = 1.376 ft (L/180)
 Two Span : Maximum Span = 1.577 ft (L/180)
 Three Span + : Maximum Span = 1.667 ft (L/180)

Width | 18.56 in
 Alloy | ASTM A792, G50 (Fy =50 ksi)
 Gauge | 24 (0.024 in)

Allowable Strength Design (ASD)
 Wind Load Factor = 1.00
 Allowable Uniform Load (psf)

Span	Deflection	Span Length (Feet)								
		2.00	2.25	2.50	2.75	3.00	3.25	3.50	3.75	4.00
1	L/180	56	44	36	29	24	21	18	15	13
	L/240	56	44	36	29	24	20	16	13	10
	L/360	56	39	29	22	17	13	10	8	7
2	L/180	56	44	36	29	24	21	18	15	13
	L/240	56	44	36	29	24	21	18	15	13
	L/360	56	44	36	29	23	18	15	12	10
3	L/180	65	51	41	34	28	24	21	18	16
	L/240	65	51	41	34	28	24	21	18	16
	L/360	65	51	41	34	28	24	20	16	13

- Formula's used in Load Tables for FLEXURE and DEFLECTION are:
 One Span - $M_p = .125wl^2$, $M_n = .125wl^2$, $x = .0130wl^4/EI$
 Two Span - $M_p = .125wl^2$, $M_n = .096wl^2$, $x = .0092wl^4/EI$
 Three Span - $M_p = .080wl^2$, $M_n = .107wl^2$, $x = .0069wl^4/EI$
 Modulus of Elasticity (E) = 29500 ksi
- Allowable uniform loads are determined per the following:
 a) Allowable Shear Stress (Fv) [AISI, C3.2]
 b) Combined Bending and Shear [AISI, C3.3]
 c) Combined Bending & Web Crippling [AISI C3.5]
- Factors of Safety used to determine uniform loads:
 FS (Bending) = 1.67
 FS (Shear) = 1.50
 FS (Web Crippling) = 1.85
- Allowance has been made for member Dead Weight.
- Minimum panel support bearing length = 2.00 in
- Concentrated load = 250 lbs at mid-span, load width = 4 in
 Simple Span : Maximum Span = 1.379 ft (L/180)
 Two Span : Maximum Span = 1.581 ft (L/180)
 Three Span + : Maximum Span = 1.672 ft (L/180)