

# Select Seam®

## Narrow Batten Installation Guide

### - Table of Contents -

<b><i>Section</i></b>	<b><i>Page</i></b>
<i>General Notes</i> .....	<i>i</i>
<i>Panel Information</i> .....	<i>1</i>
<i>Clip Information</i> .....	<i>2</i>
<i>Eave</i> .....	<i>3</i>
<i>Eave with Gutter</i> .....	<i>4</i>
<i>Eave Hem</i> .....	<i>5</i>
<i>Fascia Transition</i> .....	<i>6</i>
<i>Gable (Rake)</i> .....	<i>7</i>
<i>Side Wall (Rake Wall)</i> .....	<i>8</i>
<i>Ridge / Hip</i> .....	<i>9</i>
<i>Head Wall</i> .....	<i>10</i>
<i>High Eave</i> .....	<i>11</i>
<i>Slope Transition</i> .....	<i>12</i>
<i>Valley</i> .....	<i>13</i>
<i>Panel Lap</i> .....	<i>14</i>
<i>Batten Lap</i> .....	<i>15</i>
<i>Roof Penetrations</i> .....	<i>16</i>
<i>Roof Curb (Rake Flashing)</i> .....	<i>17</i>
<i>Roof Curb (Uphill / Downhill Flashing)</i> .....	<i>18</i>
<i>Curved Roof (Continuous)</i> .....	<i>19</i>
<i>Curved Roof (Lapped)</i> .....	<i>20</i>
<i>Curved Rake</i> .....	<i>21</i>
<i>Curved Rake Wall</i> .....	<i>22</i>
<i>Weathertightness Warranty Requirements</i> .....	<i>23</i>
<i>Snow Drag Loads</i> .....	<i>Appendix A</i>
<i>Drag Load Resistance</i> .....	<i>Appendix B</i>

## General Notes

The attached installation details are intended to be a design aid and do not depict all situations. Modifications are the responsibility of the designer/user and should take into account climate conditions such as wind and snow, governing code requirements, and the actual usage and maintenance of the structure.

### Flashings:

Where possible, flashings should be lapped away from prevailing winds. Certain flashings should be supported if it is likely that equipment (ladder, etc.) will be used against them or if foot traffic is anticipated. Check with AEP Span any time you intend to specify a prefinished flashing in a gauge or finish different than the roof panels. It is good practice to specify that all flashings be of the same material (gauge, color, finish) as the roof panels to ensure long-term durability. Field-painted flashings rarely equal the durability and color fastness of factory baked-on paint systems. The enclosed details have minimized the use of exposed fasteners where possible. The edges of flashings have also been shown hemmed to strengthen and to minimize the exposure of cut edges.

Flashing design and fabrication is generally the responsibility of the contractor. For convenience, we have provided some flashing drawings on our website at <https://www.aepspan.com/products/trims-flashings/>. Applicable Select Seam<sup>®</sup> flashing part numbers are referenced within this installation guide.

### Substrates:

Select Seam<sup>®</sup> roofing panels can be used over solid substrates only.

### Slope Requirements:

Panels should be used on slopes of 3:12 or greater. Select Seam<sup>®</sup> Narrow Batten panels can be used for curved applications. Inquire with your AEP Span Representative for details.

### Condensation, Insulation, & Ventilation:

It is the designer's responsibility to determine the need and composition of condensation control materials including insulation and vapor retarders, as well as ventilation requirements. Metal roofing is susceptible to condensation and its control should be carefully considered. Applications over rigid insulation may require solid blocking/framing for installation of perimeter flashings and drag load fasteners.

### Underlayments:

Prior to installation of metal roofing panels, it is recommended that an underlayment be installed over the roof substrate. AEP Span encourages the use of *AEP Span Underlayment HT* as it is designed specifically for use under all AEP roofing systems and is suitable for use under any metal roofing system or coping. *AEP Span Underlayment HT* is **required** by AEP Span for AEP Span Full System Weathertightness Warranties. *AEP Span Underlayment HT* is a high temperature, self-healing, self-adhering, peel and stick underlayment with a non-abrasive surface that will not mar, scratch, or abrade the underside of metal panels and flashings. Please note that additional protection may be required to meet Class A fire ratings as defined in UL790 classified assemblies.

**"Pinning" Requirements:**

The panels must only be "pinned" at one location only to resist the "drag" loads caused by the panel weight, live loads, and snow loads. The intensity of the drag load is a function of the slope, the loads involved, and the length of the panels. Panels must not be pinned at more than one location otherwise damages induced by thermal movement will occur. Appendix 'A' gives the drag loads for various slopes and snow loading conditions, and Appendix 'B' shows the number of fasteners required to resist the drag loads.

**Thermal Movement:**

Both panels and flashings must allow for thermal movement (expansion and contraction) of the materials, especially where long lengths are used. Appropriate gaps or provisions must be provided to accommodate thermal movement.

**Snow Design:**

Select Seam<sup>®</sup> panels are suitable for light snow loads only. If possible, valleys, gutters, roof elevation changes and penetrations should be minimized or eliminated in snow areas. Roof penetrations should be located as close to the ridge or peak of the roof as possible to minimize accumulations of ice and snow and the effects of thermal movement of the roof panels. Premium membrane underlayments should be used. Valleys in snow areas require special consideration due to the accumulation of snow and ice from tributary roof areas.

**Valleys:**

Valley dimensions must be the proper width to account for slope, snow, ice, and rain conditions. Valleys should receive a premium underlayment since they are susceptible to water buildup. Valleys must have positive slope for drainage and be kept

free of debris so that water does not back up and intrude under the panels.

**Oil Canning:**

Flat metal surfaces often display waviness commonly referred to as 'oil canning'. This can be caused by variations in raw material, processing variations, product handling, or variations in the substrate and roofing underlayments. Oil canning is a characteristic, not a defect, of panels manufactured from light-gauge metal. Panels are factory "corrective leveled" to minimize oil canning. Oil canning is not a cause for panel rejection. Additional information is available upon request.

**References:**

The Sheet Metal and Air Conditioning Contractors' National Association Inc. (SMACNA) manual is an excellent reference for sheet metal contractors. It's guidelines for underlayments, gutter and downspout size requirements, and expansion/contraction of metals and flashing joints should be followed.

**Technical Assistance:**

Contact your AEP Span Sales Representative for additional information.



SELECT SEAM (NARROW BATTEN):

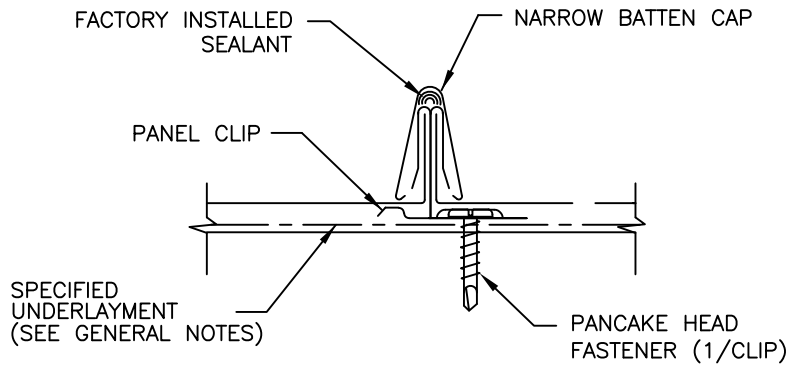
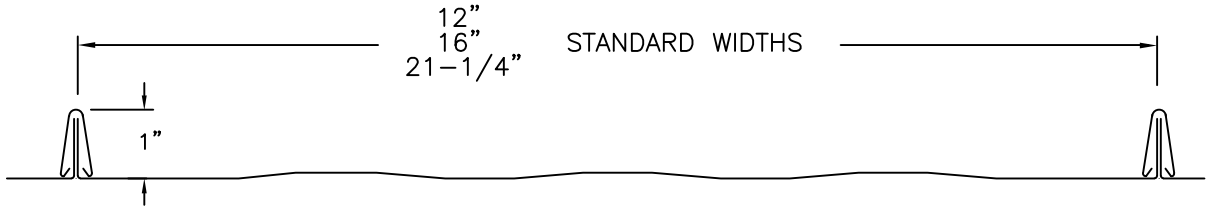

AVAILABLE MATERIALS:

STEEL: 22 & 24GA



**SELECT SEAM**  
NARROW BATTEN

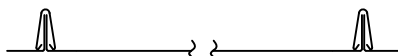

PANEL INFORMATION



SSNB-01

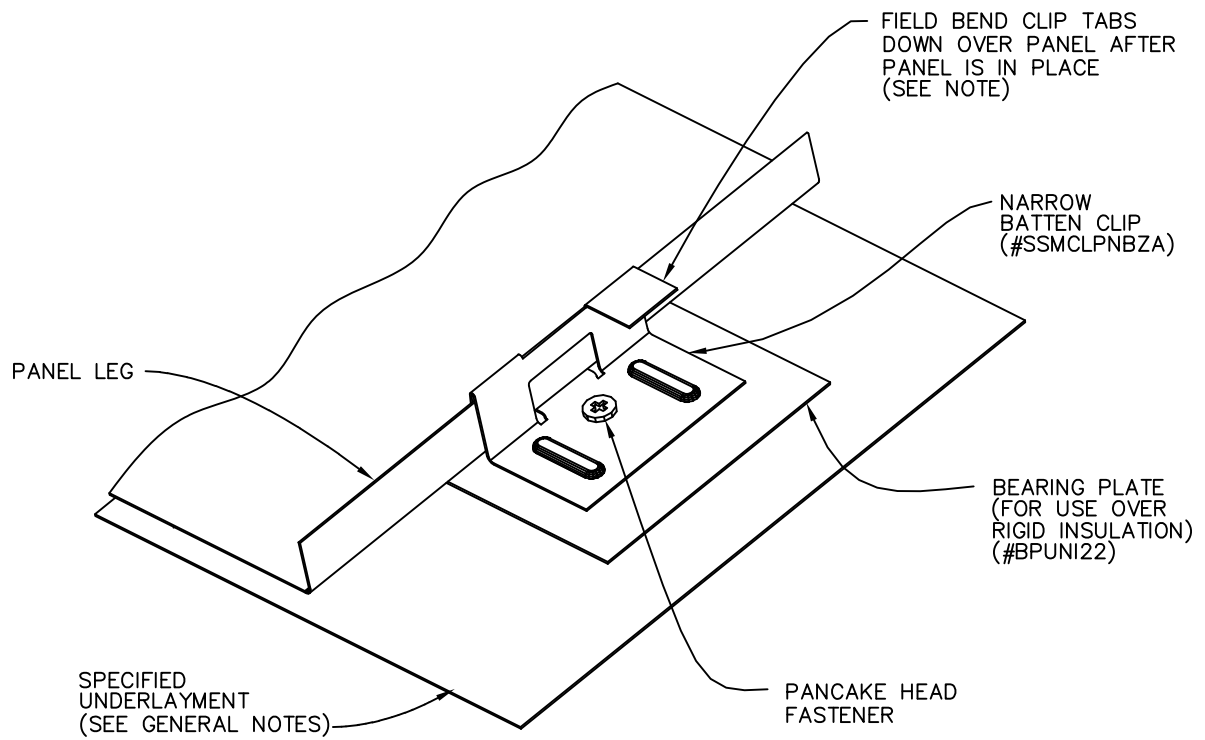

**NOTE:**

- 1) IF IT IS NECESSARY TO RAISE THE TABS OF A CLIP UP AFTER THEY HAVE BENT DOWN INTO PLACE, THE CLIP MUST BE REPLACED TO PREVENT CLIP FAILURE



**SELECT SEAM  
NARROW BATTEN**

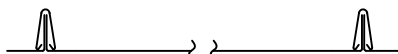

**CLIP INFORMATION**



**SSNB-02**

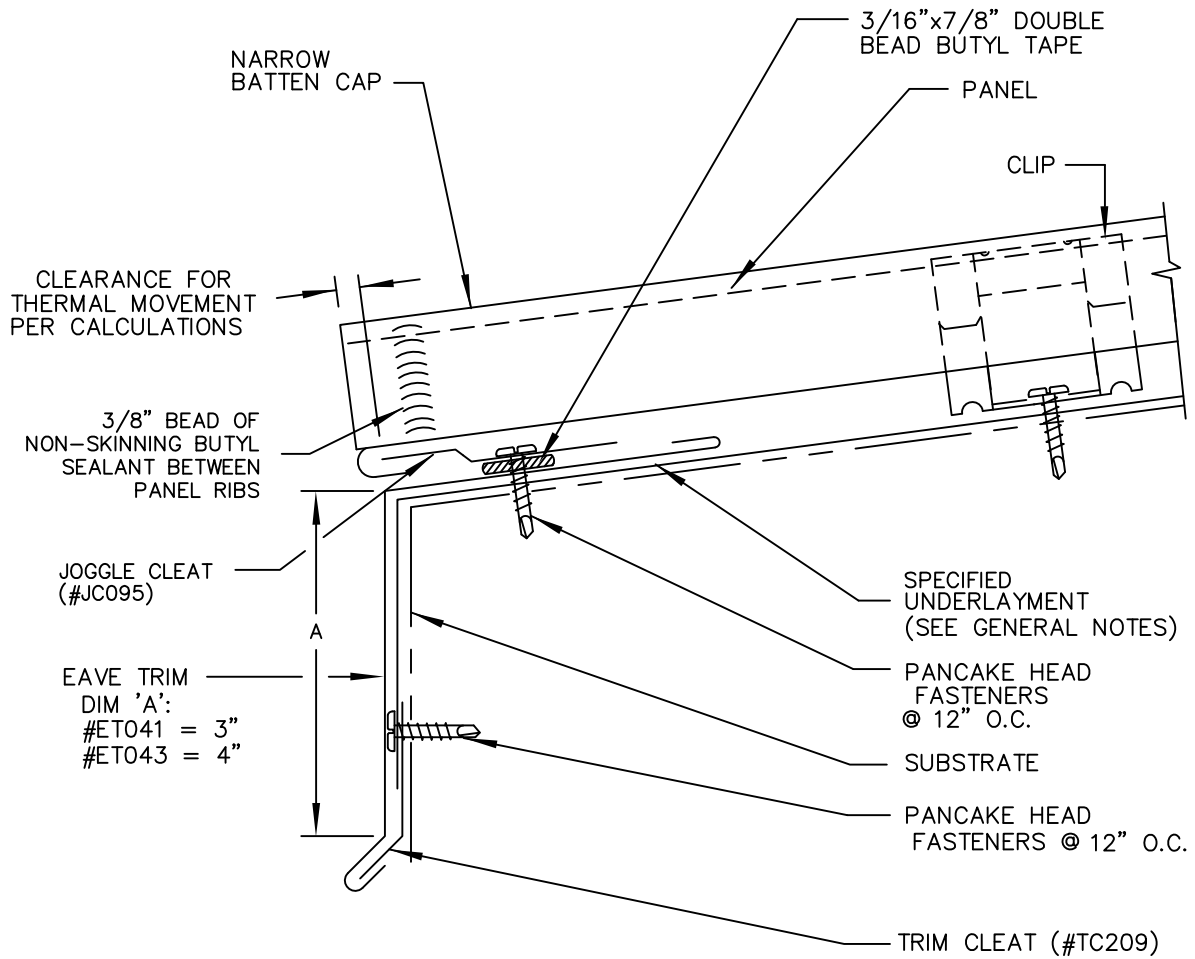

**SELECT SEAM**  
NARROW BATTEN

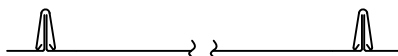

EAVE



SSNB-03

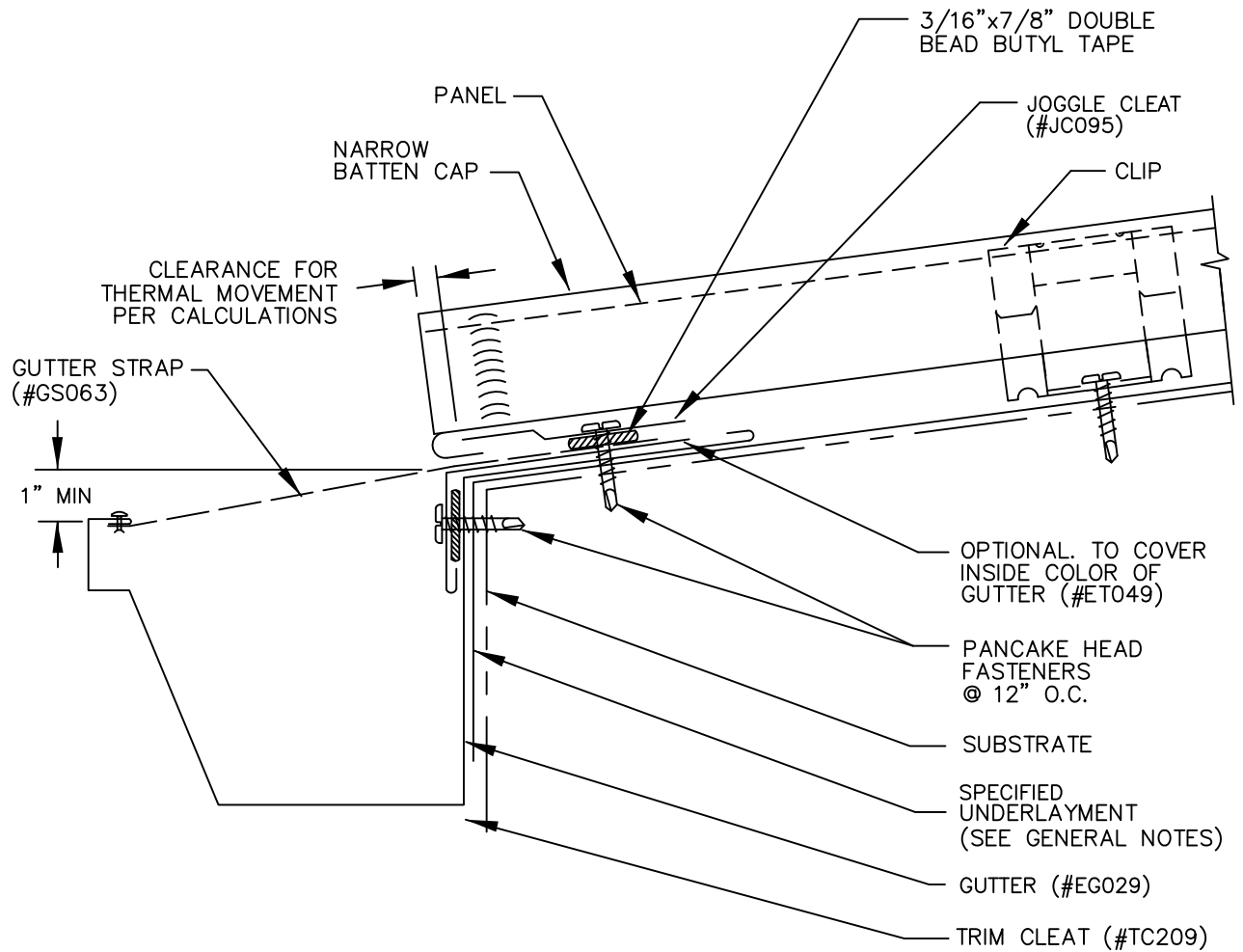

**SELECT SEAM**  
NARROW BATTEN

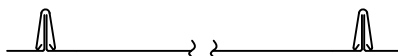

EAVE - WITH GUTTER



SSNB-04

STEP  
1

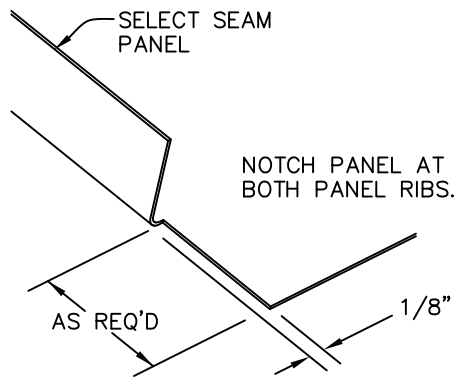

STEP  
2

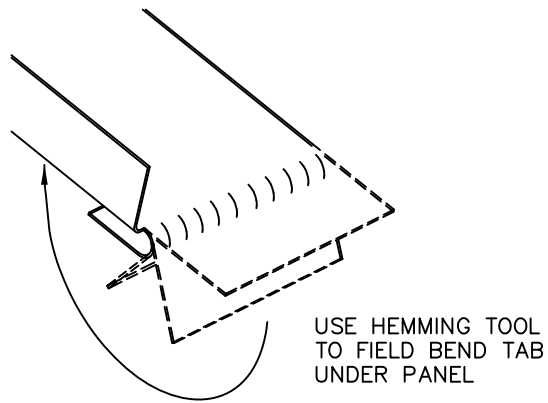

STEP  
3

APPLY 3/8" BEAD OF NON-SKINNING BUTYL SEALANT ON OUTSIDE OF MALE RIB AS SHOWN

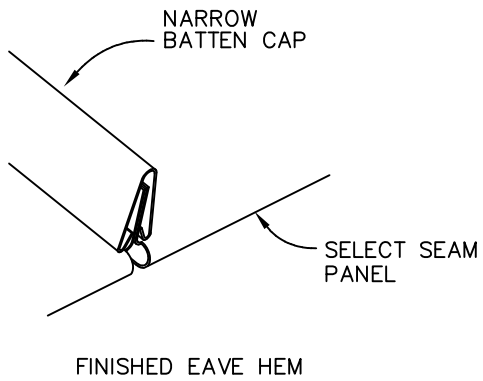
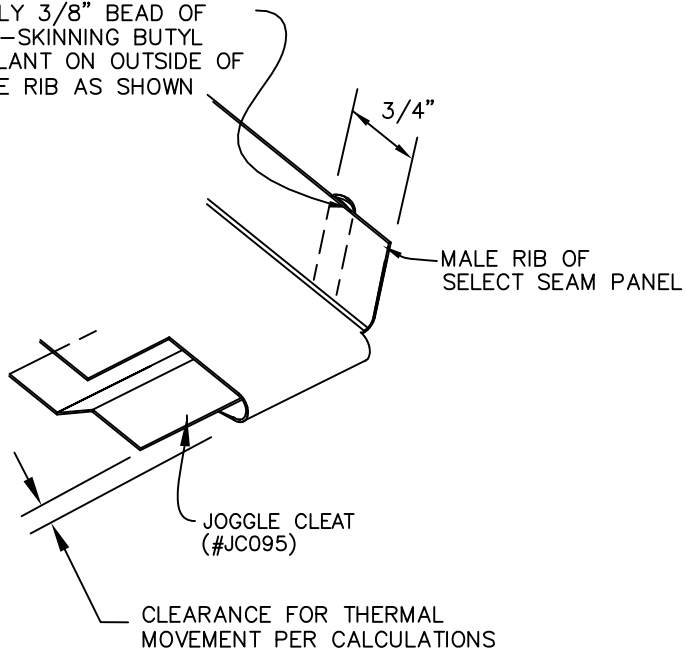

**SELECT SEAM**  
NARROW BATTEN

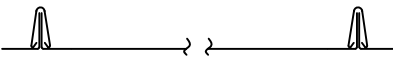

EAVE HEM



SSNB-05



FIELD CUT SIDES OF BATTEN. NOTCH  
 BOTTOM HEMS ON UPPER PORTION  
 AS REQUIRED (VARIES PER ROOF SLOPE).  
 BEND LOWER PORTION INTO PLACE.  
 APPLY NON-SKINNING SEALANT TO  
 OVERLAPS AND FASTEN IN PLACE  
 WITH 1/8" RIVETS.

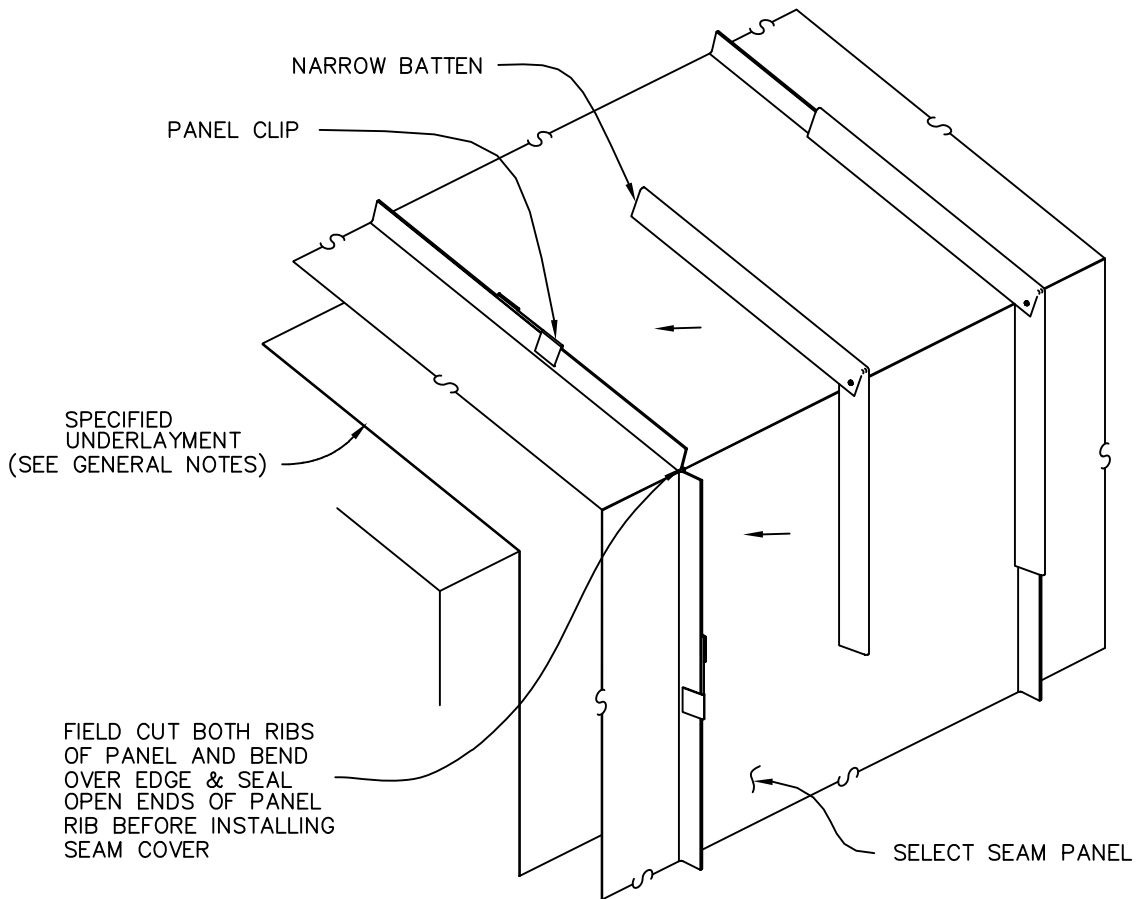
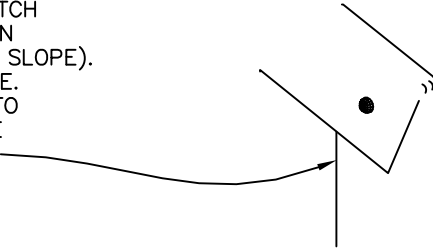

**DESIGN CAUTION:**  
 TURNING PANELS DOWN FOR  
 FASCIA MAY ESTABLISH  
 UNWANTED POINT OF PANEL  
 FIXITY.

**DESIGN NOTE:**  
 THIS TRANSITION DETAIL IS  
 NOT RECOMMENDED IN REGIONS  
 WITH HEAVY SNOW AND ICE  
 CONDITIONS.



**SELECT SEAM**  
 NARROW BATTEN

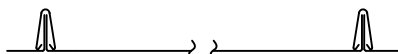

FASCIA TRANSITION



SSNB-06

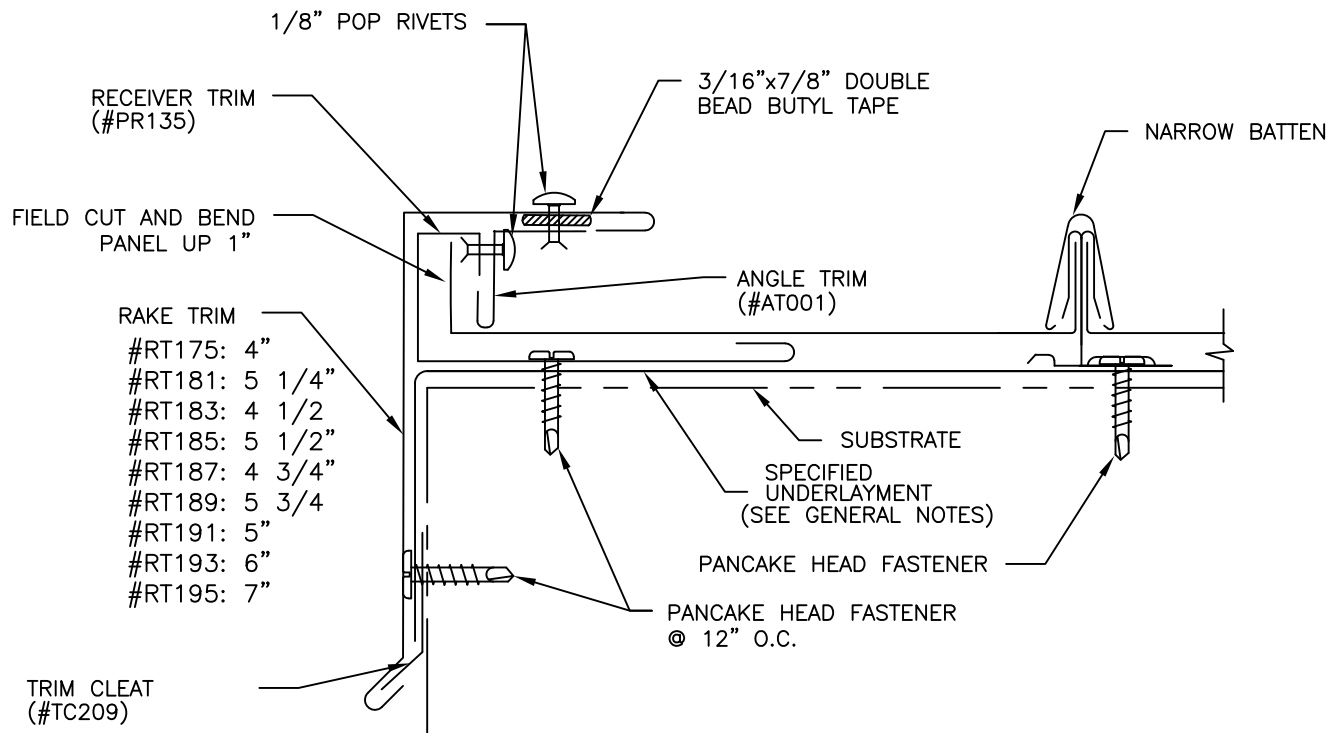

**NOTE:**  
FIELD CUT FIRST  
AND LAST PANELS  
TO EQUAL WIDTH.

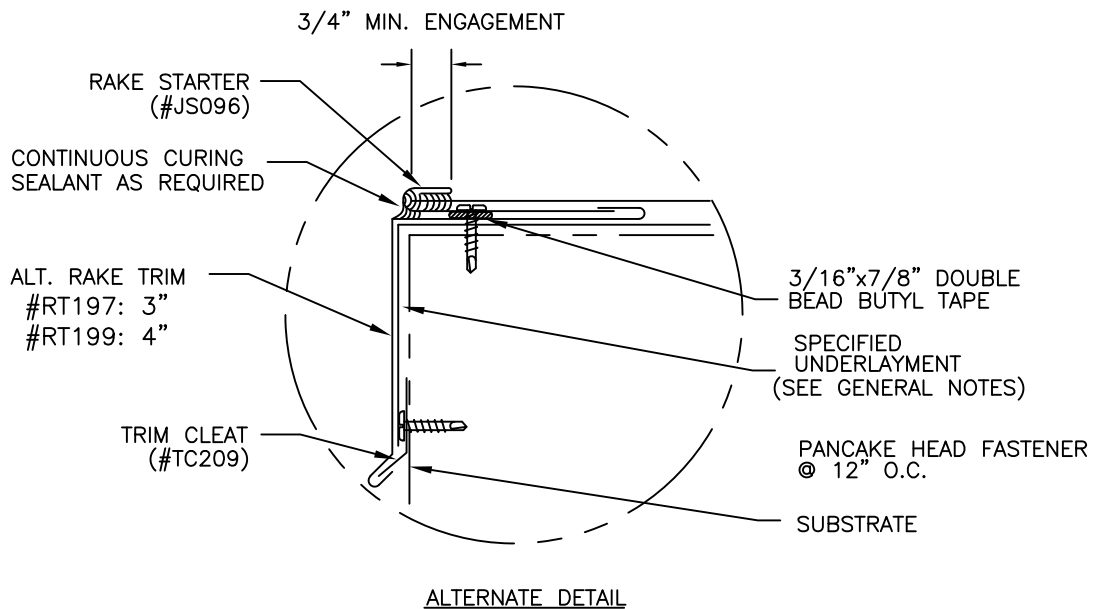

**SELECT SEAM**  
NARROW BATTEN

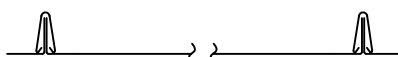

GABLE (RAKE)



SSNB-07

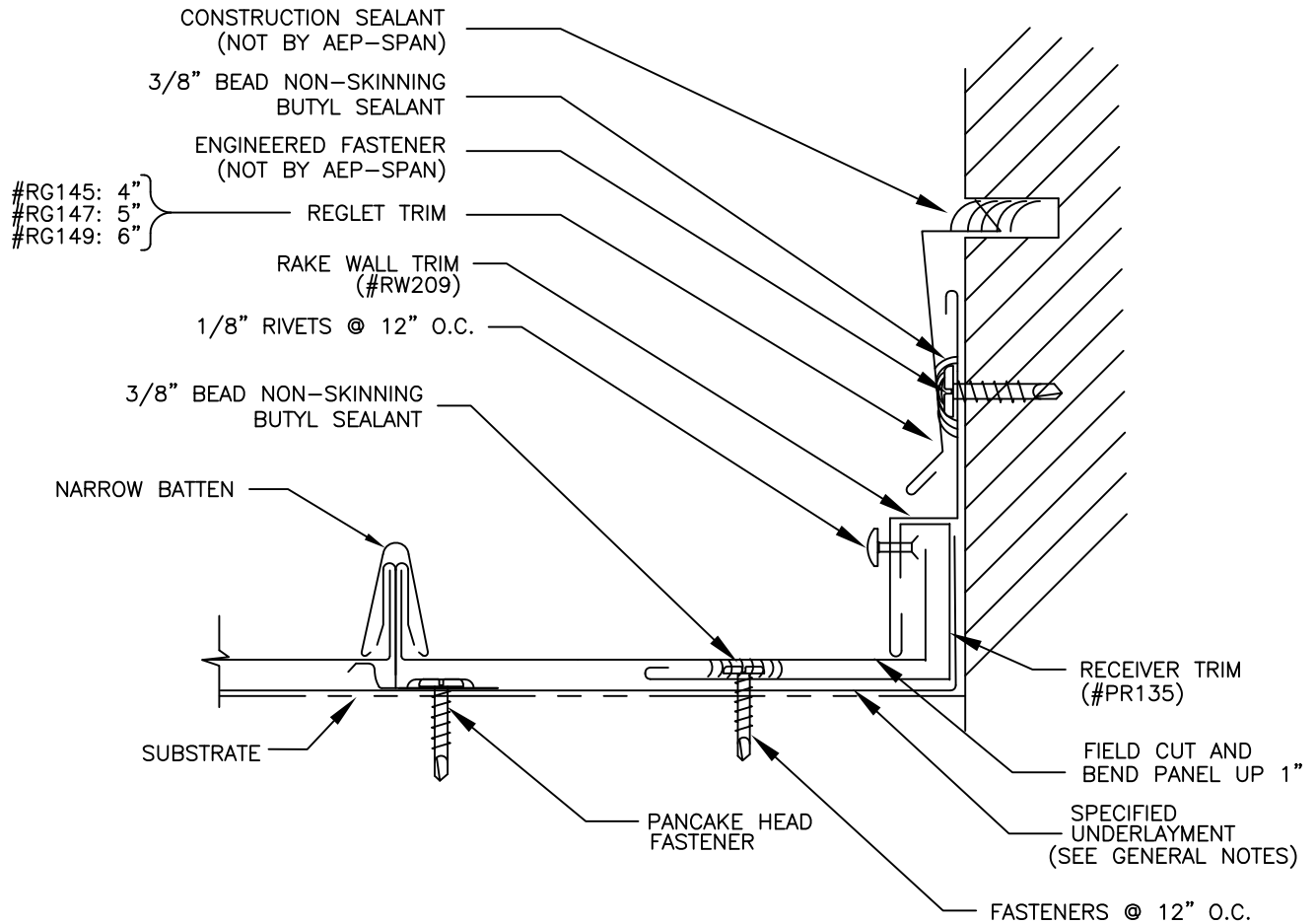

**NOTE:**  
FIELD CUT FIRST  
AND LAST PANELS  
TO EQUAL WIDTH.

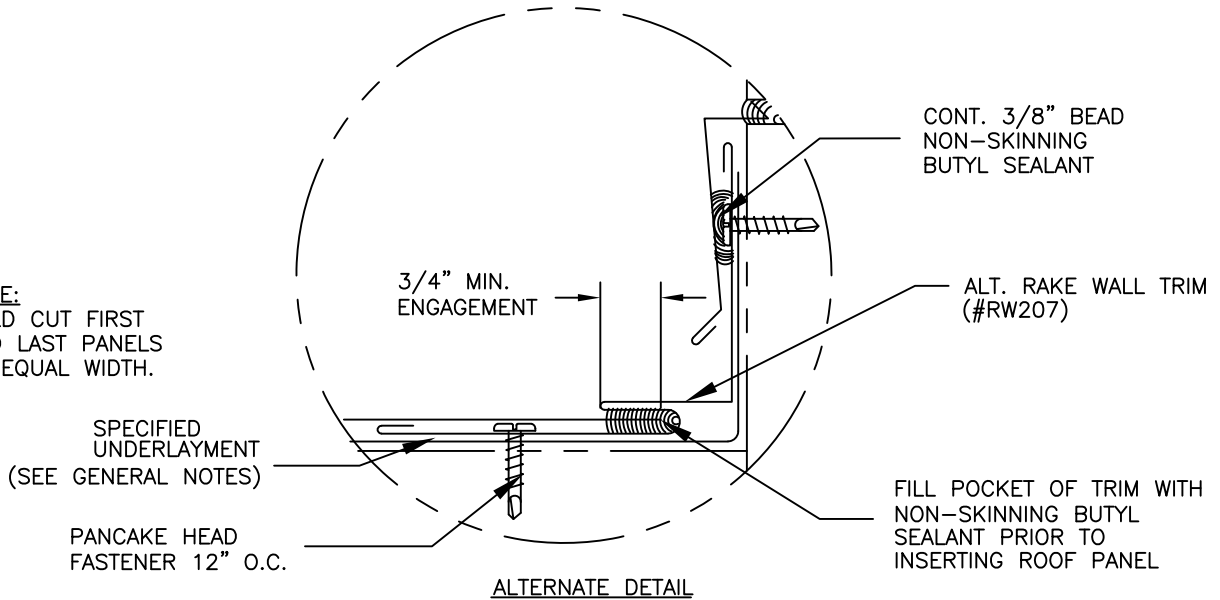

**SELECT SEAM**  
NARROW BATTEN

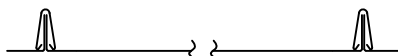

**SIDE WALL**  
(RAKE WALL)



SSNB-08

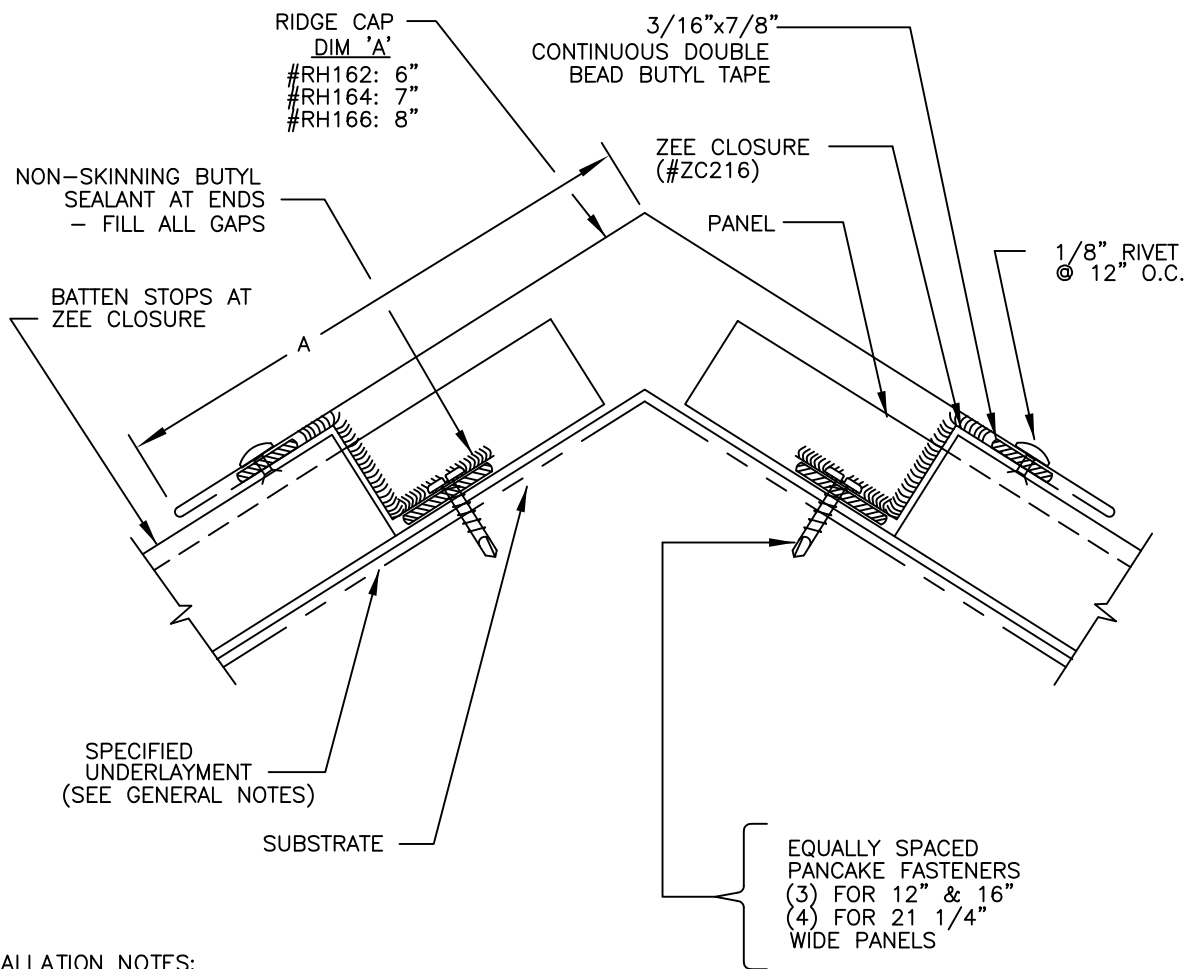
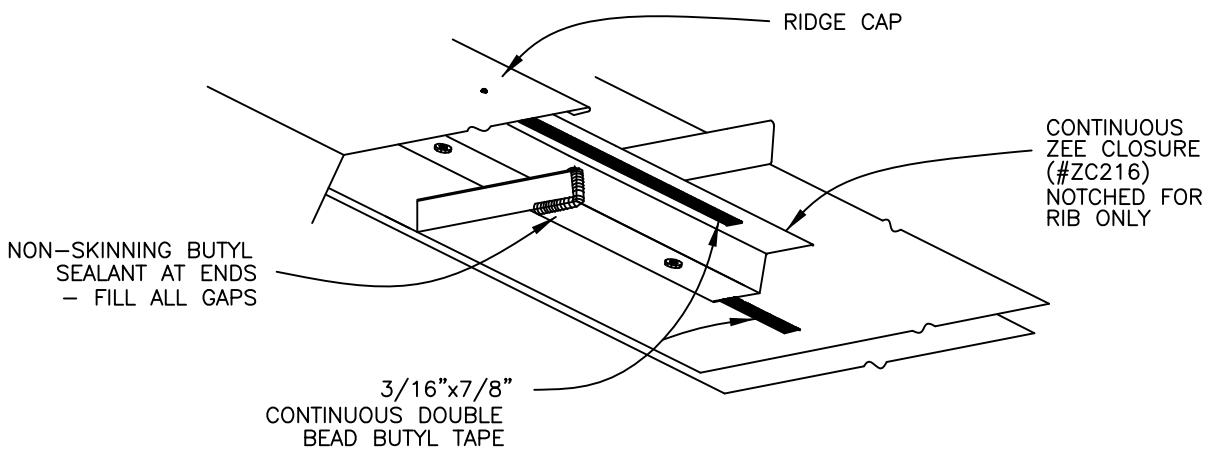

**INSTALLATION NOTES:**

- ZEE CLOSURE MUST BE CONTINUOUS AND BE NOTCHED FOR PANEL RIBS.
- BATTEN MUST STOP AT OUTSIDE FACE OF ZEE CLOSURE AND NOT PASS THROUGH.



**SELECT SEAM**  
NARROW BATTEN

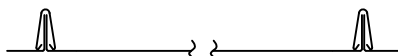

RIDGE/ HIP



SSNB-09

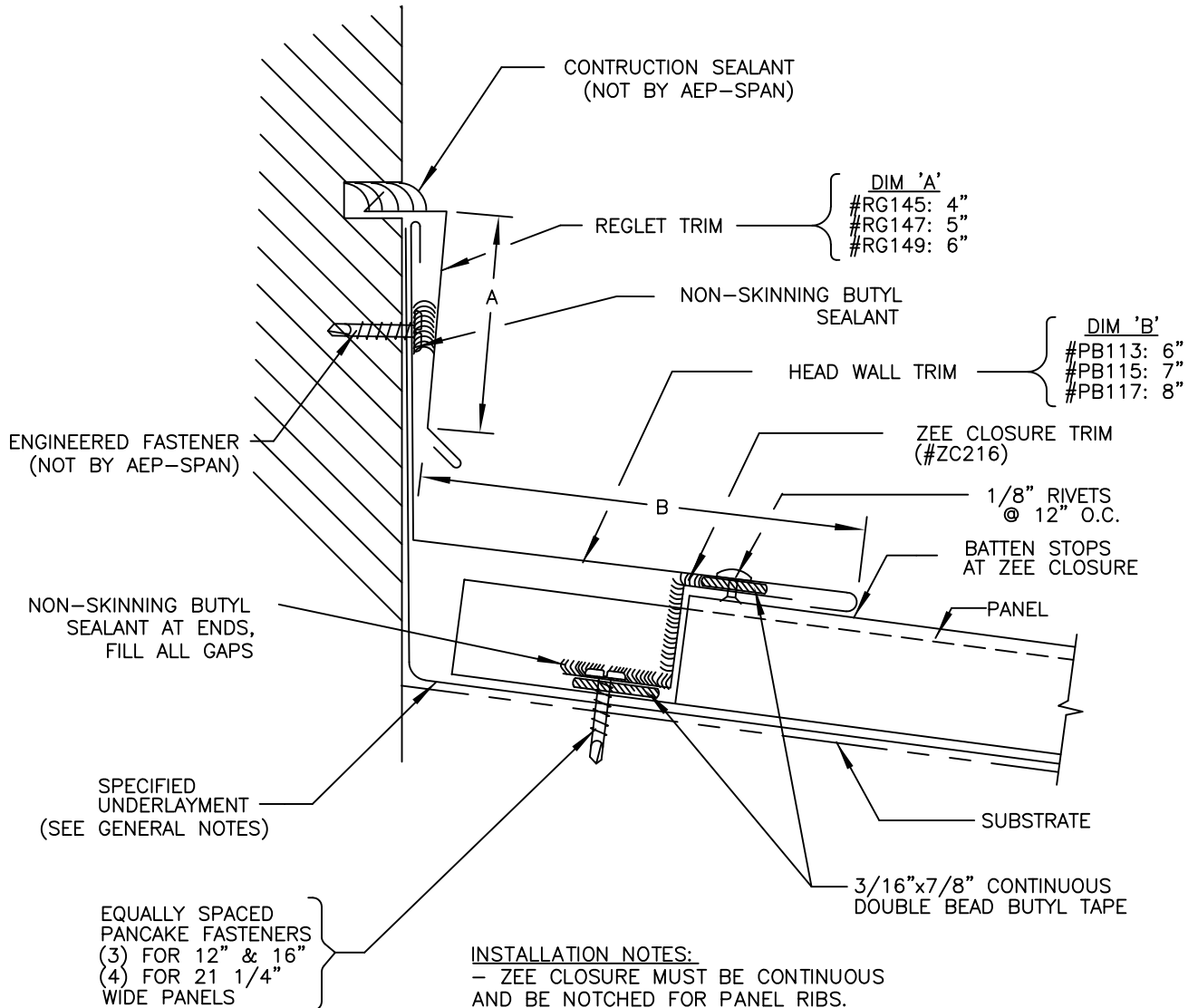
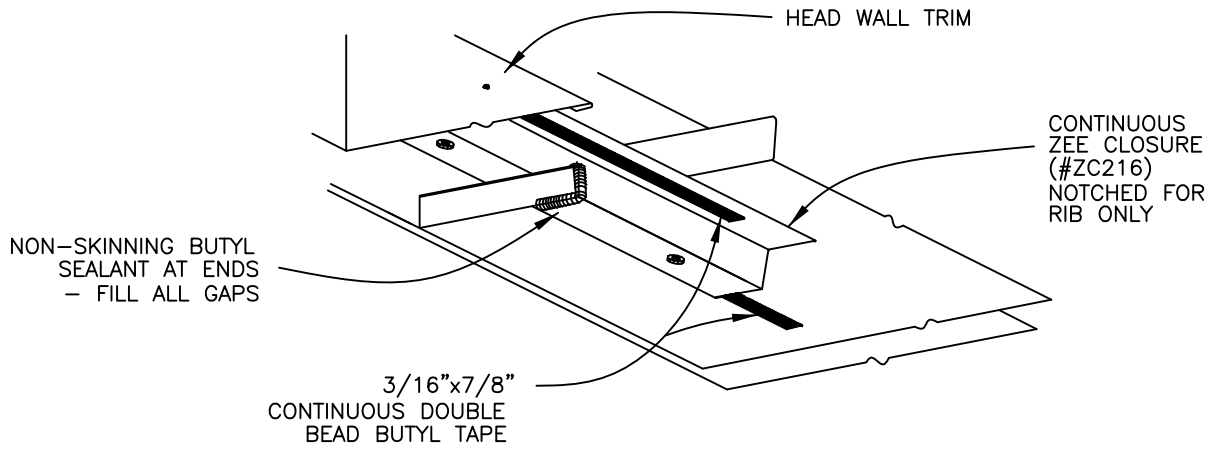

**INSTALLATION NOTES:**

- ZEE CLOSURE MUST BE CONTINUOUS AND BE NOTCHED FOR PANEL RIBS.
- BATTEN MUST STOP AT OUTSIDE FACE OF ZEE CLOSURE AND NOT PASS THROUGH.



**SELECT SEAM  
NARROW BATTEN**

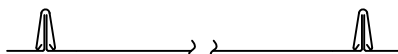

**HEAD WALL**



**SSNB-10**

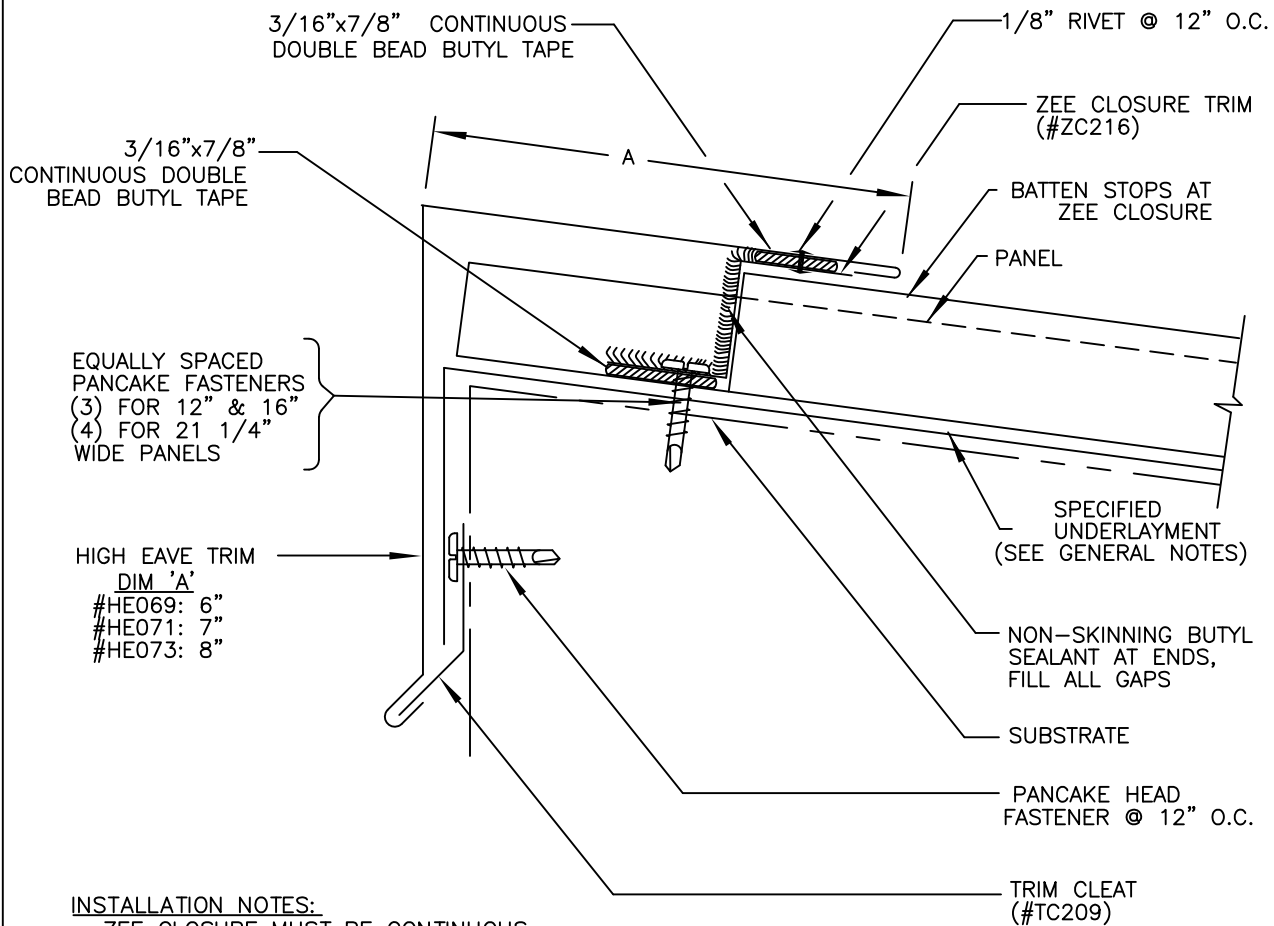
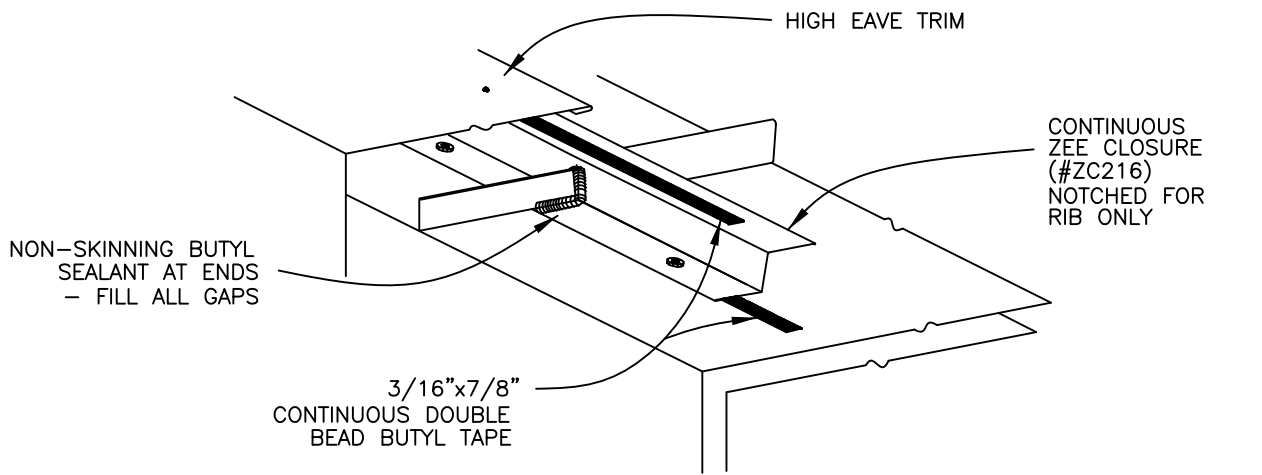

**INSTALLATION NOTES:**

- ZEE CLOSURE MUST BE CONTINUOUS AND BE NOTCHED FOR PANEL RIBS.
- BATTEN MUST STOP AT OUTSIDE FACE OF ZEE CLOSURE AND NOT PASS THROUGH.



**SELECT SEAM**  
NARROW BATTEN

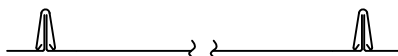

HIGH EAVE



SSNB-11

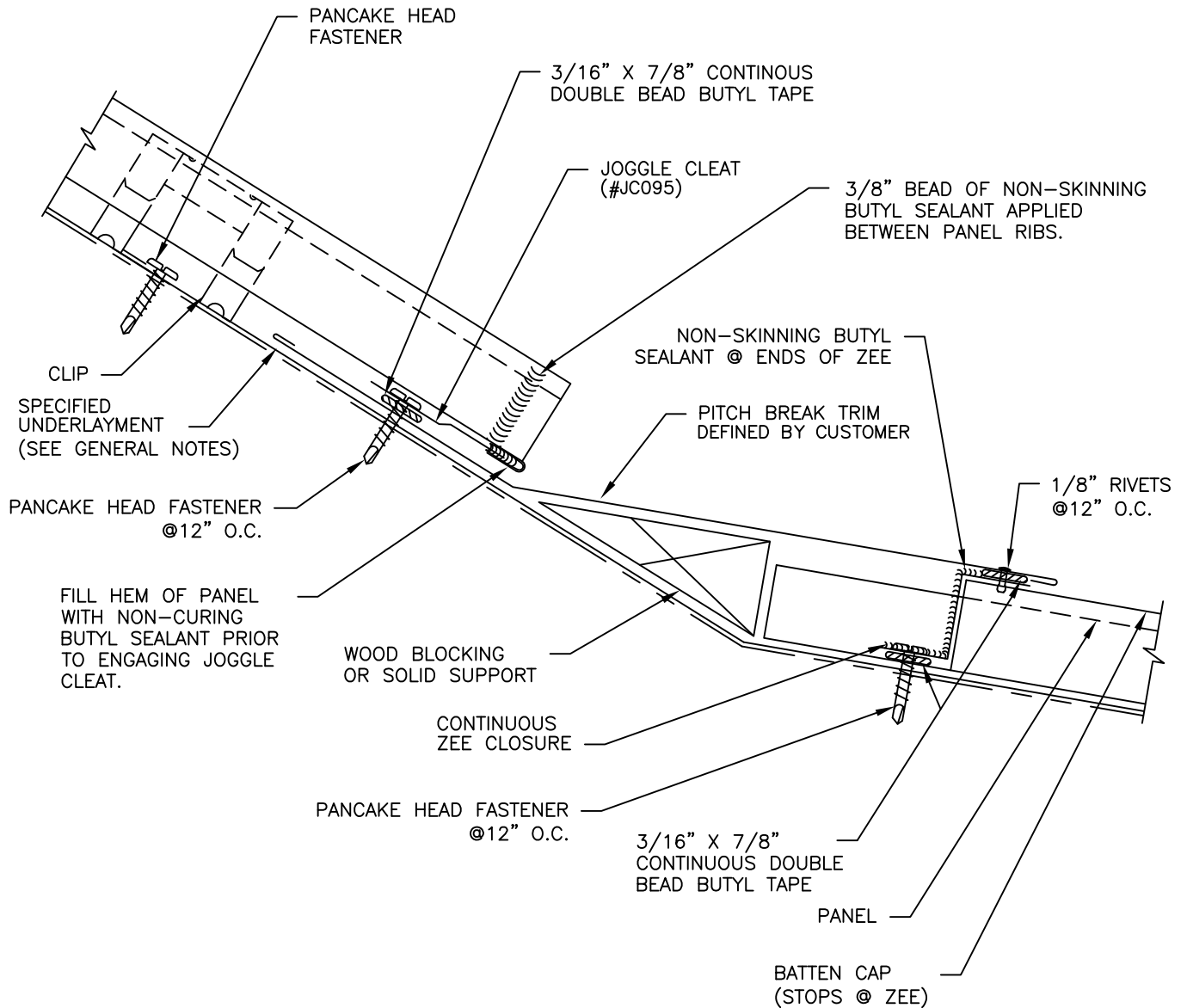

**INSTALLATION NOTES:**

- ZEE CLOSURE MUST BE CONTINUOUS AND BE NOTCHED FOR PANEL RIBS.
- BATTEN MUST STOP AT OUTSIDE FACE OF ZEE CLOSURE AND NOT PASS THROUGH.
- REFER TO EAVE & RIDGE DETAILS FOR FURTHER INFORMATION ON PROPER PANEL TERMINATIONS.



**SELECT SEAM**  
NARROW BATTEN

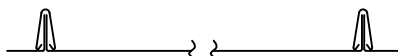

SLOPE TRANSITION



SSNB-12

JOGGLE CLEAT  
(#JC095)

PANEL

NON-SKINNING BUTYL  
SEALANT - BETWEEN  
PANEL RIBS

FIELD NOTCH AND HEM  
PANEL. FILL POCKET  
WITH NON-SKINNING BUTYL  
SEALANT BEFORE ENGAGING  
JOGGLE CLEAT.

VALLEY  
(#VF210)

SUBSTRATE

PANCAKE HEAD  
FASTENERS

12" MIN.

SPECIFIED  
UNDERLAYMENT  
(SEE GENERAL NOTES)

3/16" X 7/8" CONTINUOUS  
DOUBLE BEAD BUTYL TAPE

VALLEY SUPPORT  
(NOT BY AEP-SPAN)



### SELECT SEAM NARROW BATTEN

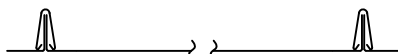

### VALLEY



SSNB-13



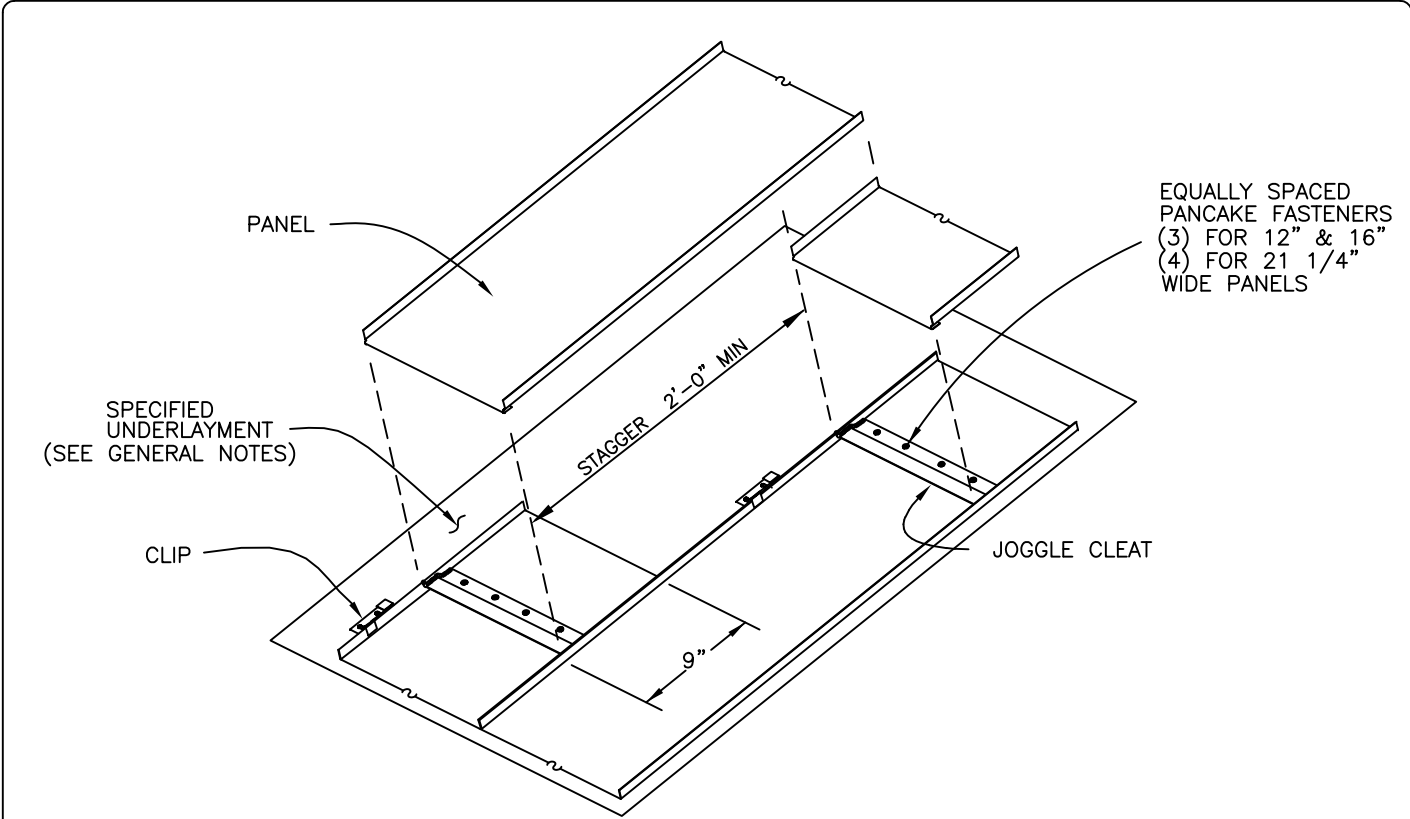

JOGGLE CLEAT (#JC095)  
 BETWEEN RIBS WITH BUTYL  
 SEALANT AT ENDS

3/8" BEAD OF NON-SKINNING  
 BUTYL SEALANT

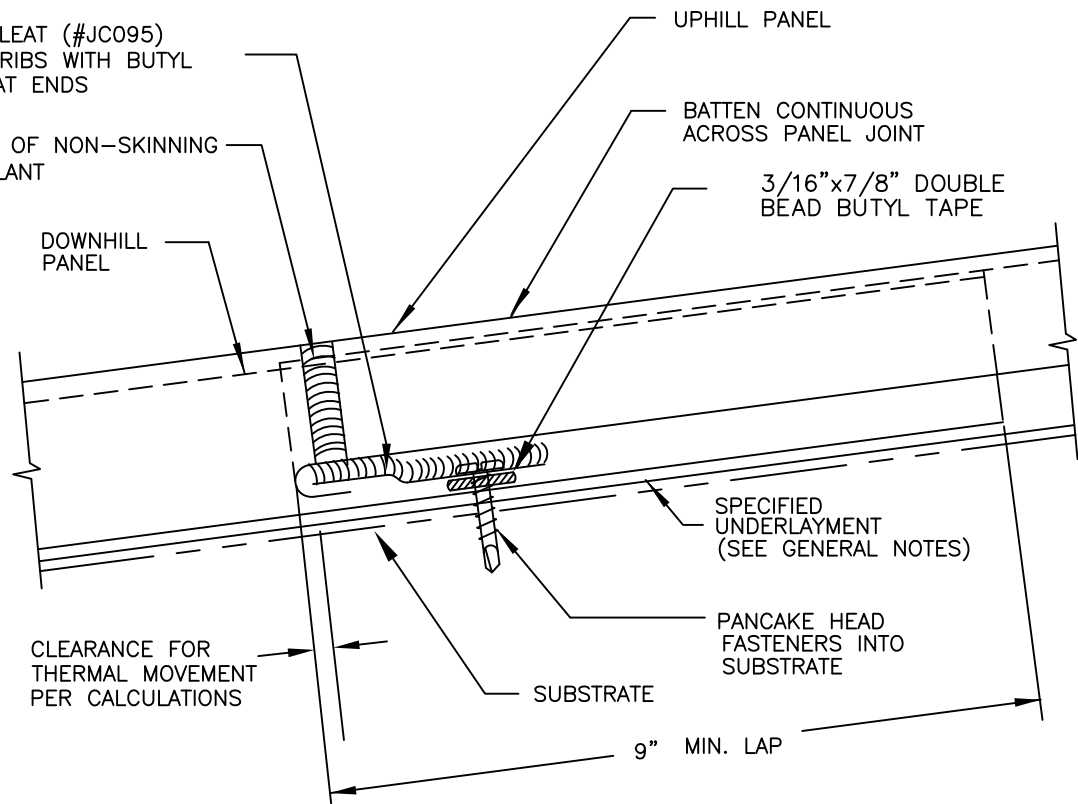

**SELECT SEAM**  
 NARROW BATTEN

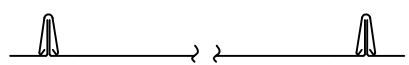

PANEL LAP



SSNB-14

SLIDE UPPER BATTEN  
OVER LOWER BATTEN 3"  
POP RIVET TOGETHER AS  
NECESSARY.

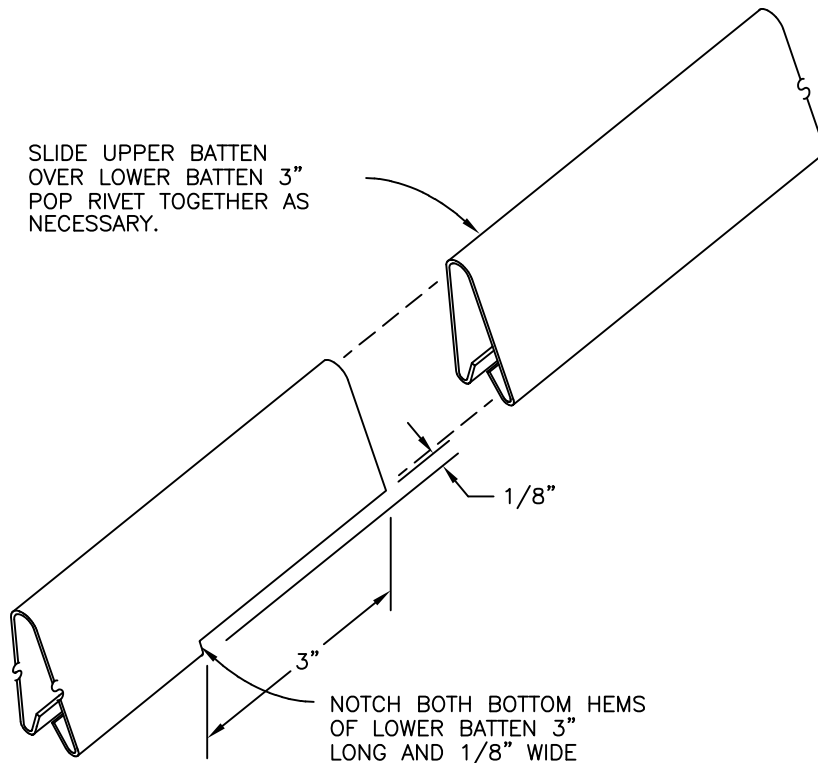

**SELECT SEAM**  
NARROW BATTEN

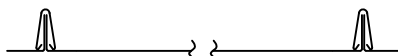

BATTEN LAP



SSNB-15

ROOF JACK

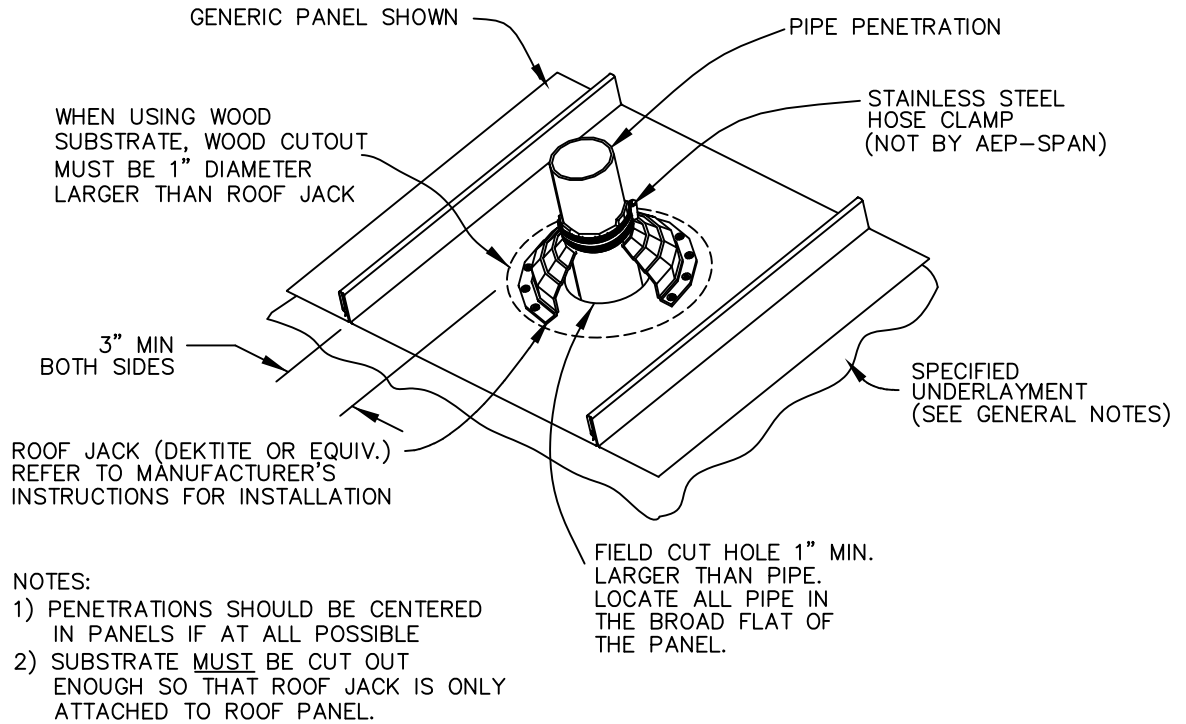

ROOF CURB

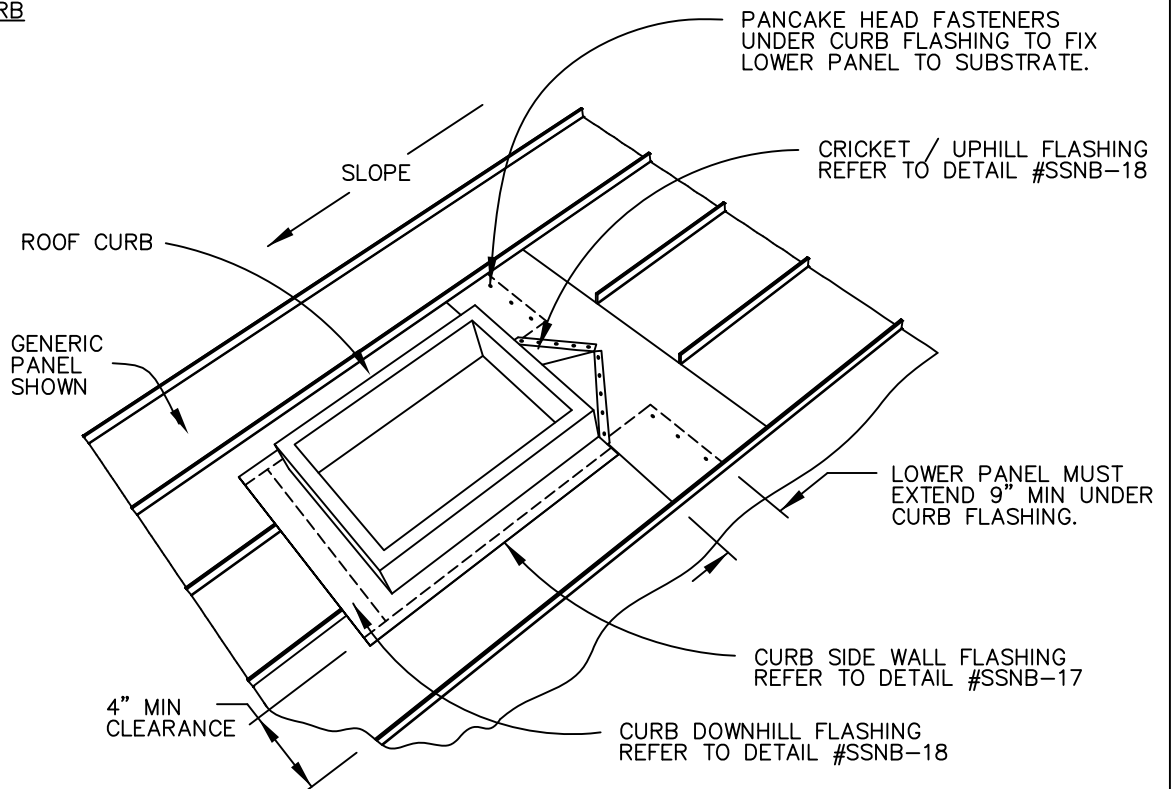

**SELECT SEAM**  
 NARROW BATTEN

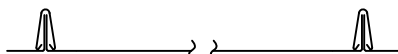

ROOF PENETRATIONS



SSNB-16

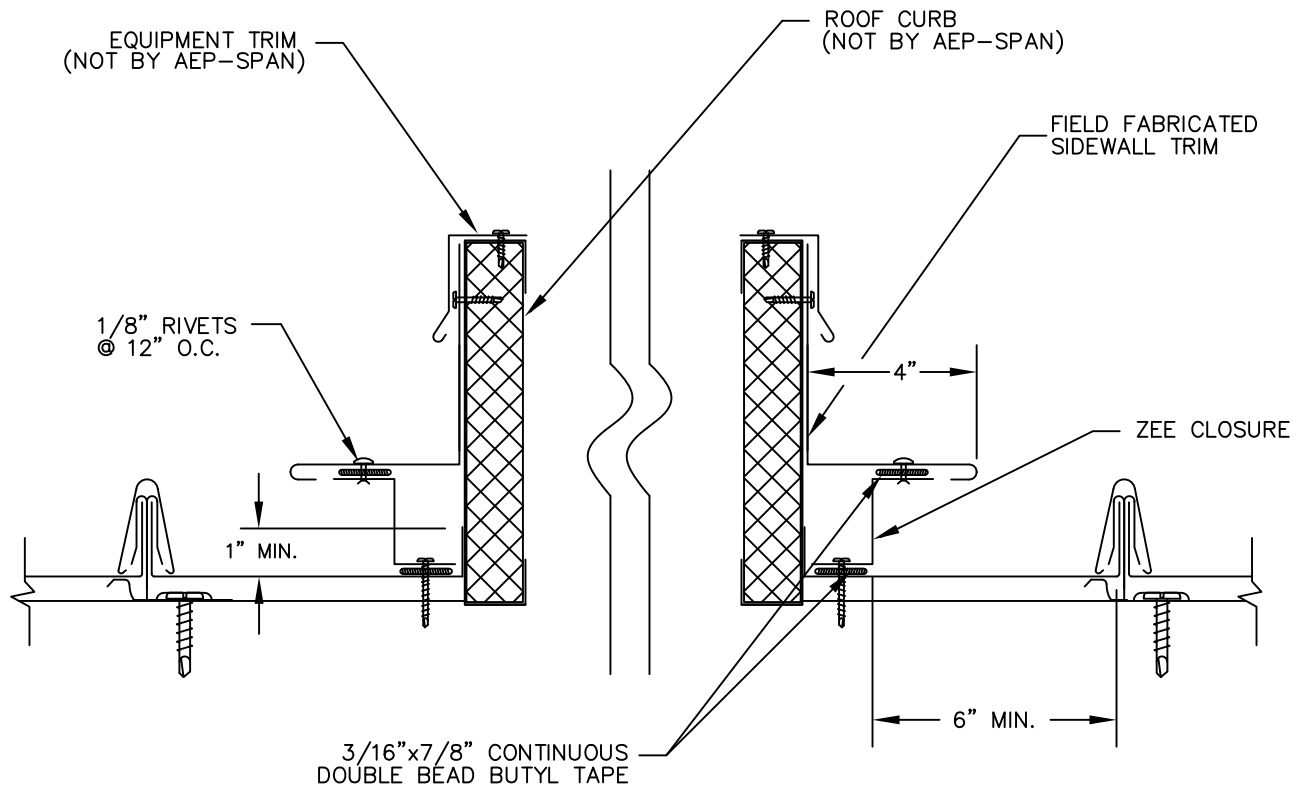

**SELECT SEAM**  
NARROW BATTEN

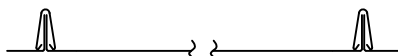

**ROOF CURB**  
(SIDE WALL FLASHING)



SSNB-17

FIELD FABRICATE CURB  
FLASHINGS FROM FLAT SHEET

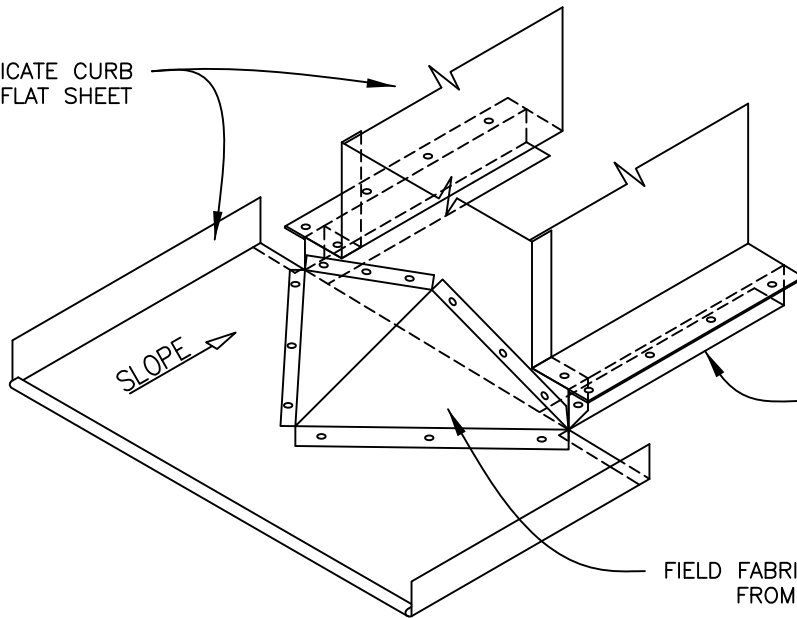

STANDARD ZEE  
CLOSURE

FIELD FABRICATE CRICKET  
FROM FLAT SHEETS

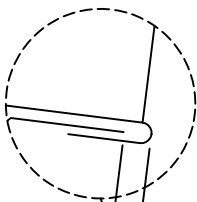

EQUIPMENT TRIM  
(NOT BY AEP-SPAN)

CLEARANCE FOR  
THERMAL MOVEMENT  
PER CALCULATIONS

FASTENER  
(NOT BY AEP-SPAN)

CRICKET TO BE  
FIELD FABRICATED  
FROM FLAT STOCK

FIELD FABRICATED  
HEADWALL TRIM

1/8" RIVET  
@ 12" O.C.

FASTENER  
(NOT BY AEP-SPAN)

8" MIN

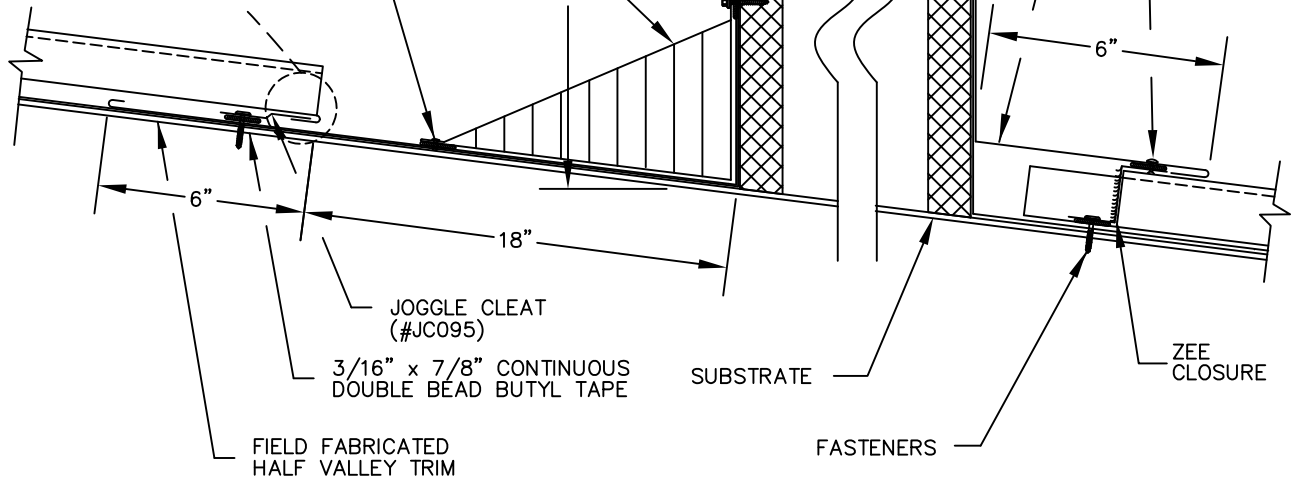

6"

6"

18"

JOGGLE CLEAT  
(#JC095)

3/16" x 7/8" CONTINUOUS  
DOUBLE BEAD BUTYL TAPE

SUBSTRATE

ZEE  
CLOSURE

FASTENERS

FIELD FABRICATED  
HALF VALLEY TRIM



### SELECT SEAM NARROW BATTEN

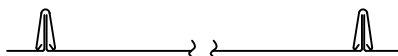

### ROOF CURB (UPHILL / DOWNHILL DETAIL)



SSNB-18

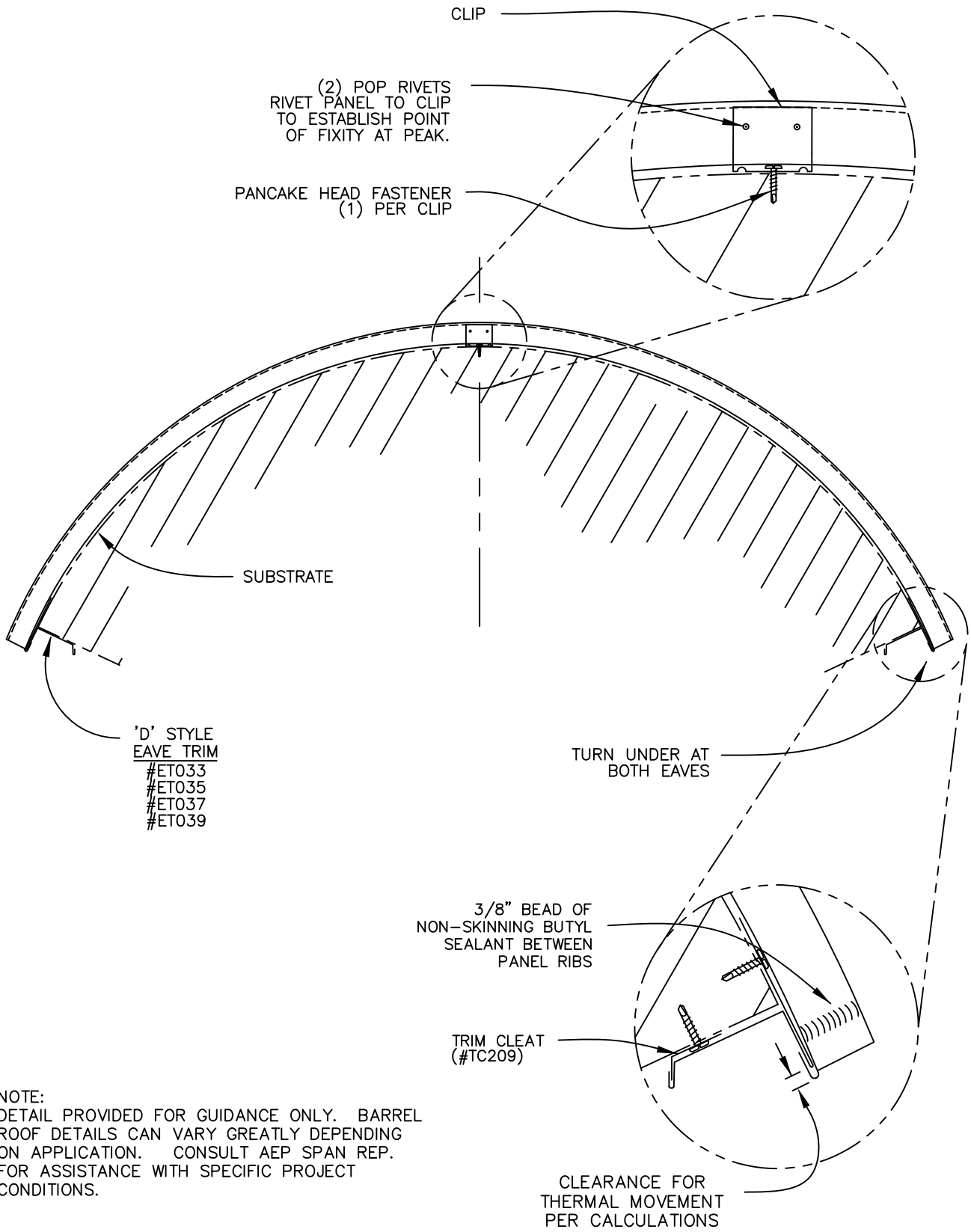

NOTE:  
 DETAIL PROVIDED FOR GUIDANCE ONLY. BARREL  
 ROOF DETAILS CAN VARY GREATLY DEPENDING  
 ON APPLICATION. CONSULT AEP SPAN REP.  
 FOR ASSISTANCE WITH SPECIFIC PROJECT  
 CONDITIONS.

CLEARANCE FOR  
 THERMAL MOVEMENT  
 PER CALCULATIONS



**SELECT SEAM**  
 NARROW BATTEN

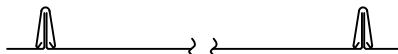

**CURVED ROOF**  
 (CONTINUOUS PANELS)



SSNB-19

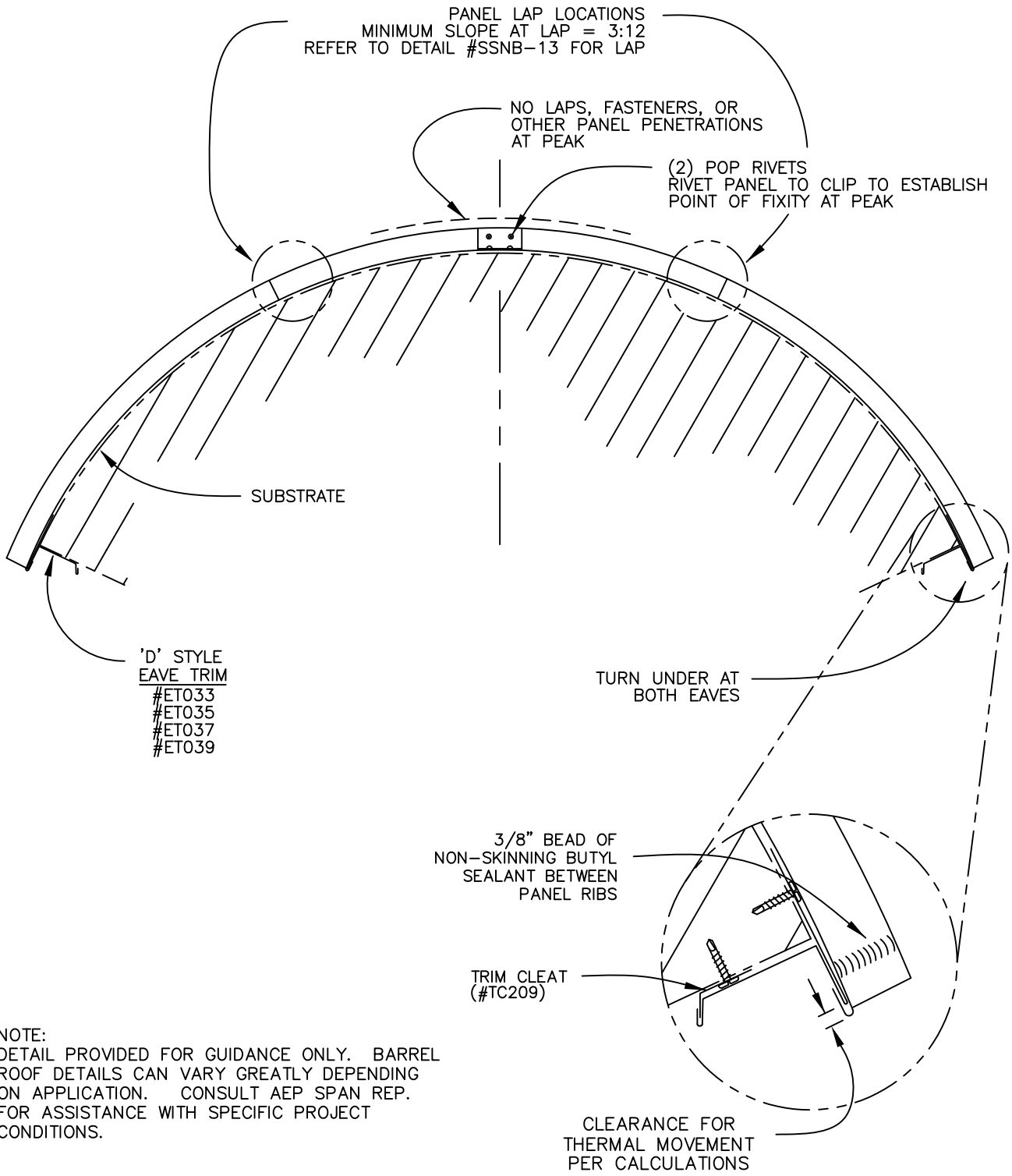

NOTE:  
DETAIL PROVIDED FOR GUIDANCE ONLY. BARREL  
ROOF DETAILS CAN VARY GREATLY DEPENDING  
ON APPLICATION. CONSULT AEP SPAN REP.  
FOR ASSISTANCE WITH SPECIFIC PROJECT  
CONDITIONS.



**SELECT SEAM**  
NARROW BATTEN

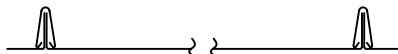

**CURVED ROOF**  
(LAPPED PANELS)



SSNB-20

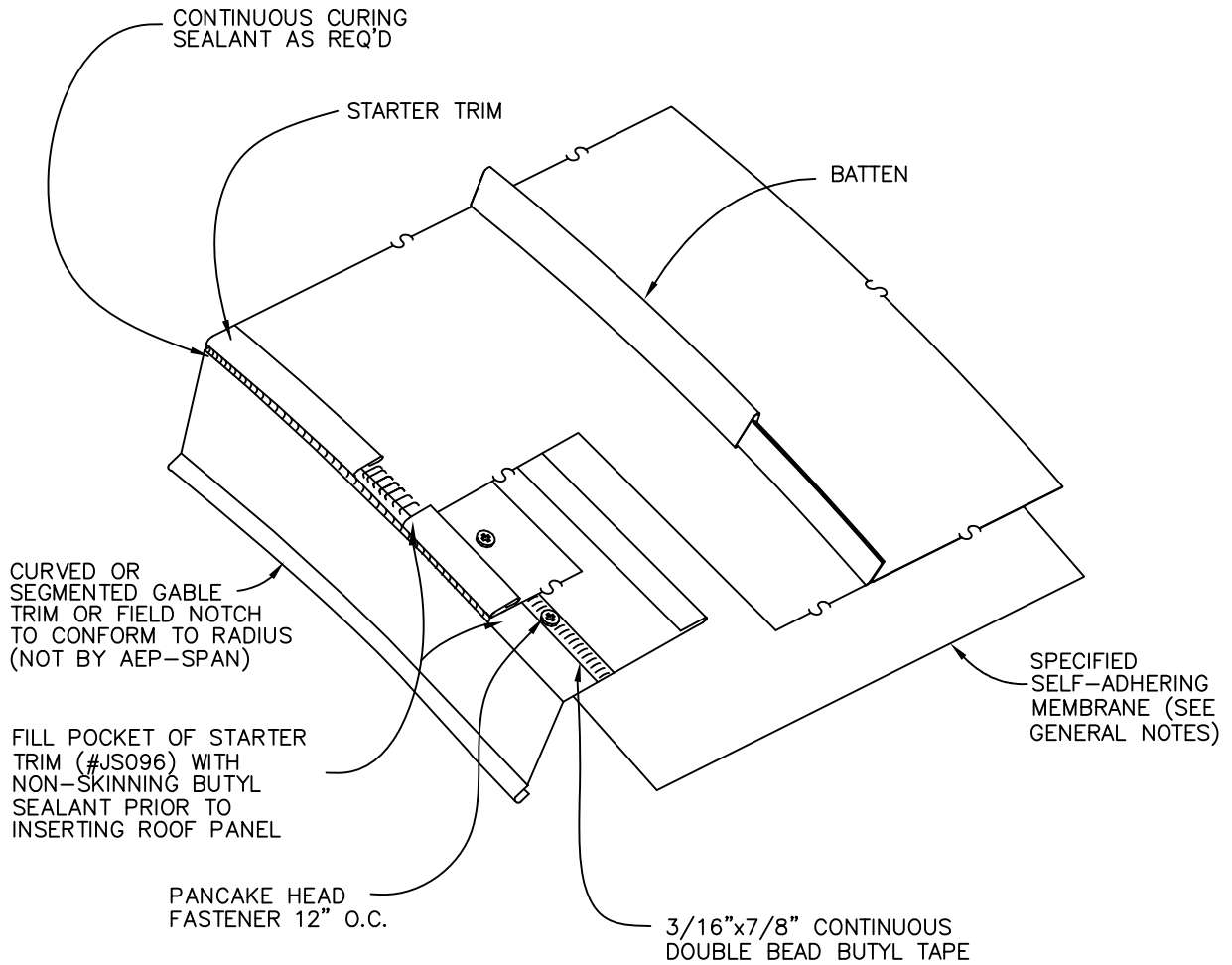

**NOTES:**

- 1) FIELD CUT FIRST AND LAST PANELS TO EQUAL WIDTH.
- 2) ALL CURVED TRIM - NOT BY AEP SPAN.



**SELECT SEAM**  
NARROW BATTEN

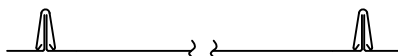

**CURVED GABLE**



SSNB-21



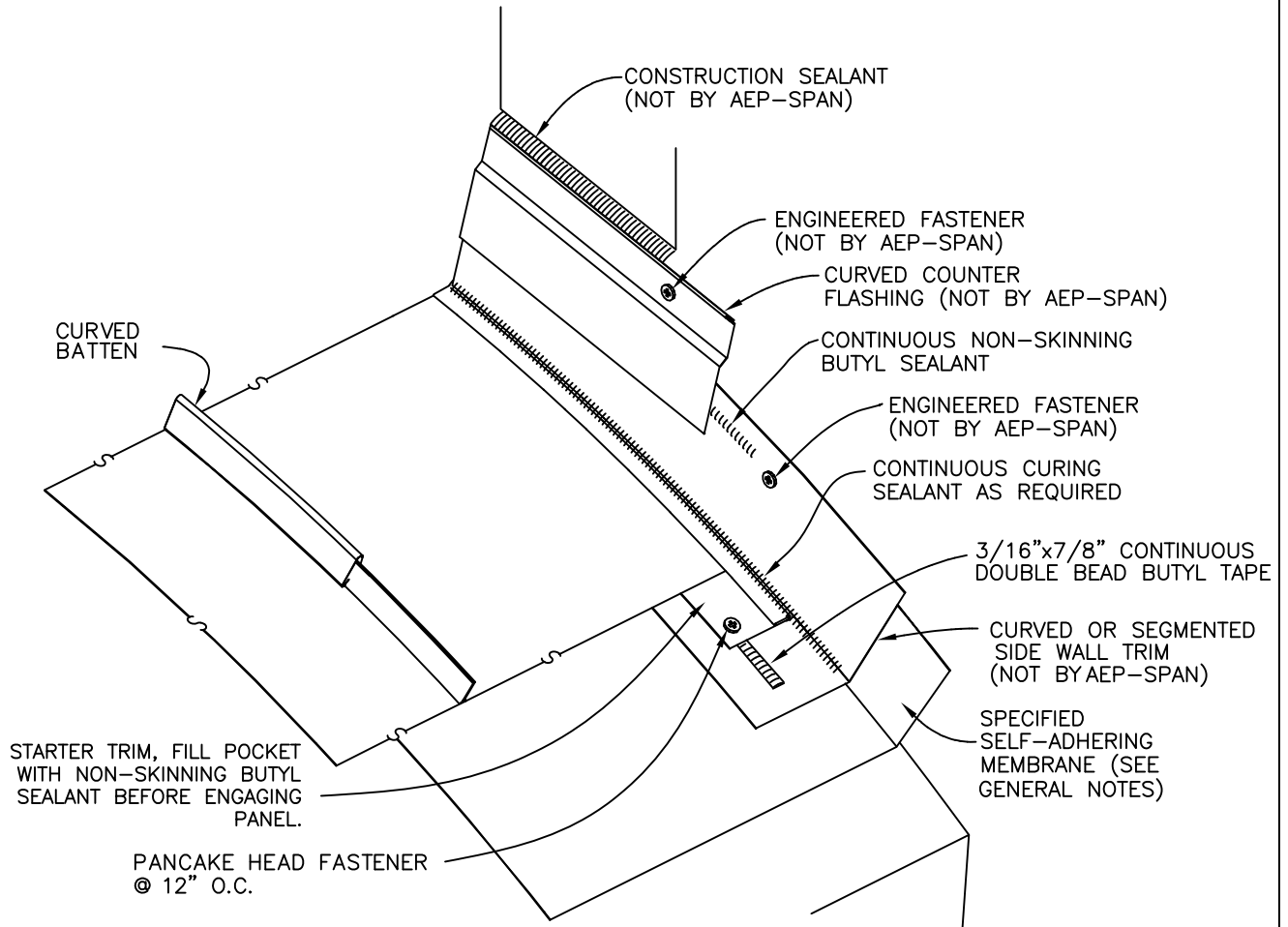

**NOTES:**

- 1) FIELD CUT FIRST AND LAST PANELS TO EQUAL WIDTH.
- 2) ALL CURVED TRIM - NOT BY AEP SPAN.



**SELECT SEAM**  
NARROW BATTEN

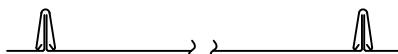

**CURVED SIDE WALL**



SSNB-22

ADDITIONAL REQUIREMENTS FOR APPLICATIONS COVERED  
BY AEP SPAN WEATHERTIGHTNESS WARRANTY (WTW)

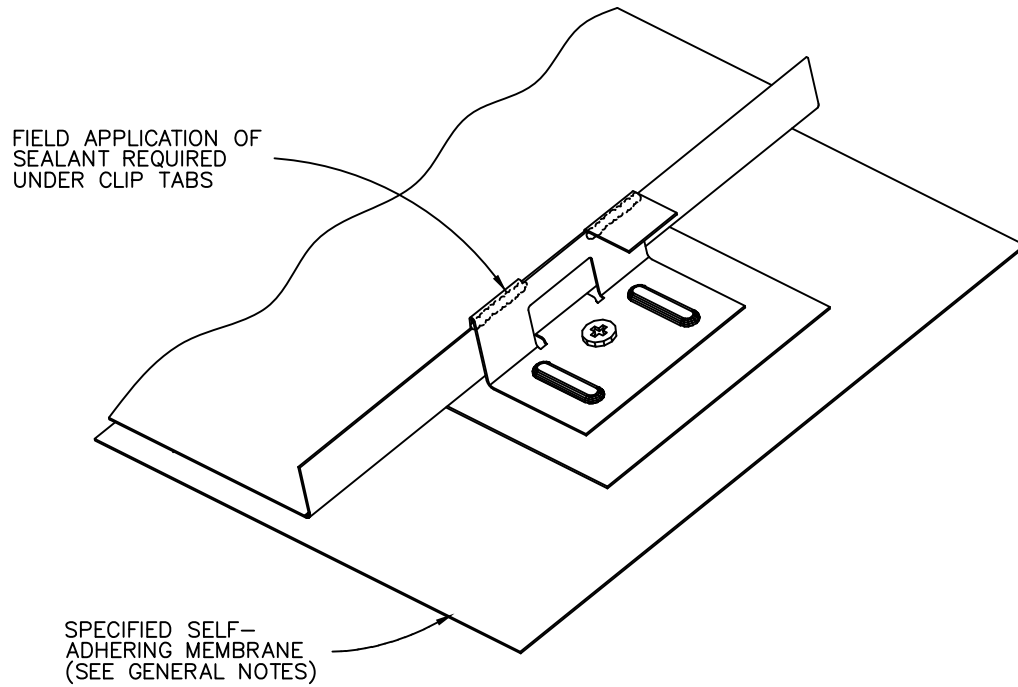

**SELECT SEAM**  
NARROW BATTEN

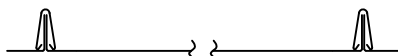

WEATHERTIGHTNESS  
WARRANTY REQUIREMENTS



SSNB-23



## Appendix A: Snow Drag Loads (lbs/ft of panel)

### Select Seam 12" Narrow Batten

Slope	Ground Snow Load, $P_g$ (psf)						
	10	15	20	25	30	35	40
	Snow Drag Load per lft of panel (lb/ft)						
3:12	2.9	4.4	5.9	7.3	8.8	10.3	11.7
4:12	3.8	5.7	7.7	9.6	11.5	13.4	15.3
5:12	4.7	7.0	9.3	11.6	14.0	16.3	18.6
6:12	5.4	8.1	10.8	13.5	16.2	18.9	21.6
7:12	6.1	9.1	12.2	15.2	18.3	21.3	24.4
8:12	6.7	10.1	13.4	16.8	20.1	23.5	26.8
9:12	7.3	10.9	14.5	18.2	21.8	25.4	29.0
10:12	7.7	11.6	15.5	19.4	23.2	27.1	31.0
11:12	8.2	12.3	16.4	20.4	24.5	28.6	32.7
12:12	8.6	12.8	17.1	21.4	25.7	29.9	34.2

### Select Seam 16" Narrow Batten

Slope	Ground Snow Load, $P_g$ (psf)						
	10	15	20	25	30	35	40
	Snow Drag Load per lft of panel (lb/ft)						
3:12	3.9	5.9	7.8	9.8	11.7	13.7	15.7
4:12	5.1	7.7	10.2	12.8	15.3	17.9	20.4
5:12	6.2	9.3	12.4	15.5	18.6	21.7	24.8
6:12	7.2	10.8	14.4	18.0	21.6	25.3	28.9
7:12	8.1	12.2	16.3	20.3	24.4	28.5	32.5
8:12	8.9	13.4	17.9	22.4	26.8	31.3	35.8
9:12	9.7	14.5	19.4	24.2	29.0	33.9	38.7
10:12	10.3	15.5	20.7	25.8	31.0	36.1	41.3
11:12	10.9	16.4	21.8	27.3	32.7	38.2	43.6
12:12	11.4	17.1	22.8	28.5	34.2	39.9	45.6

### Select Seam 21 1/4" Narrow Batten

Slope	Ground Snow Load, $P_g$ (psf)						
	10	15	20	25	30	35	40
	Snow Drag Load per lft of panel (lb/ft)						
3:12	5.2	7.8	10.4	13.0	15.6	18.2	20.8
4:12	6.8	10.2	13.6	16.9	20.3	23.7	27.1
5:12	8.2	12.4	16.5	20.6	24.7	28.8	33.0
6:12	9.6	14.4	19.2	24.0	28.7	33.5	38.3
7:12	10.8	16.2	21.6	27.0	32.4	37.8	43.2
8:12	11.9	17.8	23.8	29.7	35.7	41.6	47.5
9:12	12.9	19.3	25.7	32.1	38.6	45.0	51.4
10:12	13.7	20.6	27.4	34.3	41.2	48.0	54.9
11:12	14.5	21.7	29.0	36.2	43.4	50.7	57.9
12:12	15.2	22.7	30.3	37.9	45.5	53.0	60.6

#### Notes:

- To determine drag load forces per panel, multiply the tabulated value by the panel length. Then refer to Appendix B for fastener schedule.
- Values assume Ground Snow Load ( $P_g$ ) is provided. Drag Loads may be reduced if actual Roof Snow Loads ( $P_s$ ), per ASCE-7, are provided by customer.
- For roof slopes and snow loads greater than listed above, please contact your AEP Span representative.



## Appendix B:

## Drag Load Resistance

Fastener Type	Substrate	Capacity (lbs)	Number of Fasteners per Panel									
			2	3	4	5	6	7	8	9	10	
#12-14 x 1" SD HWH	16ga Steel min.	234	468	702	936	1170	1404	1638	1872	2106	2340	
1/4-14 x 7/8" Lap SD HWH	22ga Steel min.	184	368	552	736	920	1104	1288	1472	1656	1840	
#14 x 1" Type A Mill. Point HWH	1/2" Plywood min.	128	256	384	512	640	768	896	1024	1152	1280	
#14 x 1" Type A Mill. Point HWH	2x Douglas Fir	57	114	171	228	285	342	399	456	513	570	
#10-16 x 1" SD Pancake Head	16ga Steel min.	206	412	618	824	1030	1236	1442	1648	1854	2060	
#10-16 x 1" SD Pancake Head	22ga Steel min.	154	308	462	616	770	924	1078	1232	1386	1540	
#10-12 x 1" Type A Pancake Head	1/2" Plywood min.	108	216	324	432	540	648	756	864	972	1080	
#10-12 x 1" Type A Pancake Head	2x Douglas Fir	54	108	162	216	270	324	378	432	486	540	

### Example:

16" Select Seam Narrow Batten attached to 1/2" plywood.

4:12 slope

30psf snow load

40ft maximum panel length

a) From Appendix A, find the drag load per linear foot of panels: 4:12 & 30psf snow load = 15.3lbs/ft

b) Multiply the load by the panel length = 15.3lbs/ft X 40ft = 612lbs drag load per panel.

c) Find the drag load in Appendix B.

The nearest value is 648 lbs for Qty=6, #10-12 x 1" Type A Pancake Head fasteners.

### Notes:

- Contact your AEP Span representative if there are any questions regarding the use of these appendices.
- Fasteners must be located a minimum of 1" from each other and from the end of the panel.
- Fastener capacities per AISI S100, NASPEC, and APA recommendations.

Rev.4-20-20